

L36

High-Intensity LED PAR36 Warning Signal



INSTALLATION GUIDE



36 Doctor Foote Rd. Colchester CT 06415
Tel: (860) 537-3471 • Fax: (860) 537-0656
www.strobe.com

TECHNICAL SPECIFICATIONS

INPUT VOLTAGE 12.8V (10 to 16 Volts DC)
INPUT CURRENT 0.65A Average, 1.25A Peak
LIGHT OUTPUT AMBER: 276+ LUMENS
 BLUE: 215+ LUMENS
 RED: 276+ LUMENS
 WHITE: 770+ LUMENS
WIRE LENGTH 1 FT
LED ELEMENTS 7
FLASH PATTERNS 16 (8 Standard, 8 optional cycle)
MAX NUMBER OF SYNC'D HEADS 64
WARRANTY PERIOD 5 YEARS

MOUNTING

The L36 will fit into any PAR36 size housing. Some housings require the included rubber spacer for a proper fit. Peel the paper off the adhesive backing and apply to back of L36 light head.

The L36 with rubber housing mounts using one 5/16" bolt.

The L36 with flush mount bezel will mount to any flat surface. Use the bezel as a template to mark the hole locations.

DIMENSIONS

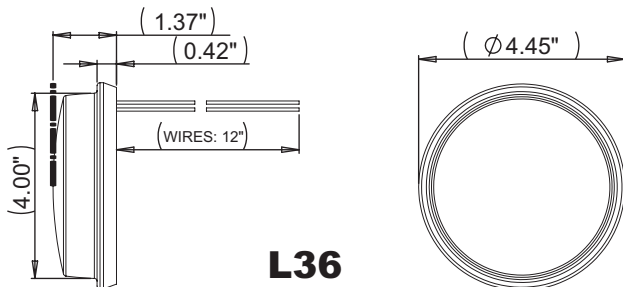

L36

ELECTRICAL CONNECTIONS

RED: +V

Connect to +V through an ON/OFF switch. The use of a fuse located close to the voltage source is recommended. Size the fuse according to the number of heads used in the system. 18AWG or larger wire is recommended.

BLACK: - GROUND

Connect to - GROUND *vehicle chassis*. 18AWG or larger wire is recommended.



BLUE: Flash pattern SYNC and SELECTION wire.

If you wish to have all the LED heads synchronize their flash timings and patterns with each other then all the BLUE wires must be connected together. (64 Heads Maximum) The BLUE wire is also used to select the flash pattern. Touch the BLUE wire to +V to select the next pattern in the FLASH PATTERN LIST. The BLUE wire can also be run to a momentary push-button located on the dashboard to allow the flash pattern to be changed when desired.

Note: Do not connect the BLUE wire to - Ground. It will disrupt the flash pattern sync signal.

YELLOW: Alternating / Simultaneous selection.

The BLUE wires of all L36 heads must be connected together for the alternating / simultaneous function to work.

Connect to either +V or GROUND (GND).

The YELLOW wire makes the head fire AT THE SAME TIME or ALTERNATING with the other heads in the system.

Heads with YELLOW connected to +V fire at the same time.

Heads with YELLOW connected to GND fire at the same time.

Heads with YELLOW connected to +V will ALTERNATE with heads that have YELLOW connected to GND.

The YELLOW wire has no function in STEADY ON mode.

TWO COLOR: Two color heads will always alternate flash the two colors. The YELLOW wire will select which colors flash at the same time and which alternate.

The L36 will also synchronize with any BULL LED™, HIDE-A-LED™, or SD24 head. The wiring colors and functions are identical.

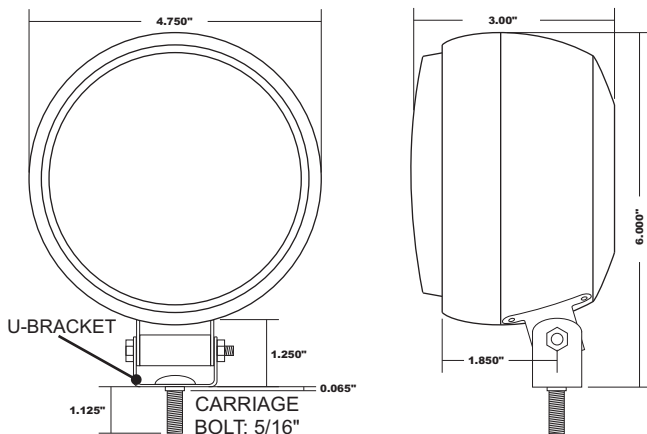

L36 IN RUBBER HOUSING

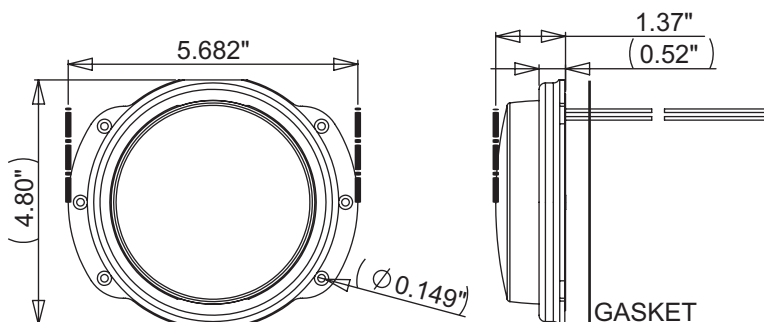

L36 FLUSH MOUNT

FLASH PATTERNS

POWER-UP RESET:

After installing the system it is best to do a POWER-UP RESET the first time to ensure that all heads are in sync. Touch **BLUE** wires to +V (**RED** wire) while applying power. Release **BLUE** wires. All heads will reset to Pattern #2. *If you have installed a pattern select pushbutton, press and hold pattern select while turning power switch ON.*

To select a flash pattern, touch **BLUE** to +V or press pattern select switch to increment the flash pattern. The heads will remember the selected pattern even if power is removed.

STANDARD PATTERNS			
#	Pattern:	Frequency:	Description:
1	Quad Flash	1.25 Hz	75 Quad Flashes Per Minute.
2	Double Flash	1.25 Hz	75 Double Flashes Per Minute.
3	Triple Flash	1.53 Hz	92.3 Triple Flashes Per Minute.
4	DeciBlast	1.42 Hz	85.5 Deci Flashes Per Minute.
5	Single Flash	1.25 Hz	75 Single Flashes Per Minute.
6	Mega Flash	1.90 Hz	114 Single Flashes Per Minute.
7	Triple+Burst	1.37 Hz	82.5 Triple+Burst Flashes Per Minute.
8	Steady On		Steady On. SPLIT COLOR = FAST MEGA
CYCLE PATTERNS			
9	Cycle All		Cycle through patterns 1 to 7.
10	Double-Triple+Burst		2 Double, 2 Triple+Burst cycle.
11	Cycle Classic		1 Double, 1 Quad, 2 Mega cycle.
12	Quad-Mega		3 Quad, 4 Mega cycle.
13	Single-Quad		2 Single, 2 Quad cycle.
14	DeciBlast-Quad		2 DeciBlast, 2 Quad cycle.
15	Single-Triple-DeciBlast		2 Single, 2 Triple, 2 DeciBlast cycle.
16	Mega-Triple+Burst		1 Mega, 1 Triple+Burst cycle.

STANDARD PATTERNS:

In order to maintain compatibility with older products, the L36 ships with only the standard patterns enabled (1 through 8).

CYCLE PATTERNS:

You may add patterns 9 through 16 by following this procedure:
1) Touch **BLUE** wires to +V (**RED** wire) while applying power. *If you have installed a pattern select pushbutton, press and hold pattern select while turning power switch ON.*

2) Hold **BLUE** wires on +V for 5 SECONDS (heads will not be flashing during this time). After 5 SECONDS the heads will flash once or twice to indicate the flash pattern list that has been selected:

ONE FLASH = Standard Patterns only.

TWO FLASHES = Standard + Cycle patterns.

3) Remove the BLUE wires from +V (or release pushbutton).

To switch back to only the standard patterns repeat the procedure. You may switch the pattern set at any time as many times as you wish. All heads will remember the pattern set that was selected even when power is removed.

SEALING WIRE CONNECTIONS

THE WIRE CONNECTIONS MUST BE SEALED IF USED IN A WET LOCATION. WATER WILL CORRODE THE WIRES AND ALSO CAUSE SYNC PROBLEMS.

ELECTRICAL TAPE WILL NOT SEAL A CONNECTION WE RECOMMEND AN RTV SILICONE SEALANT.

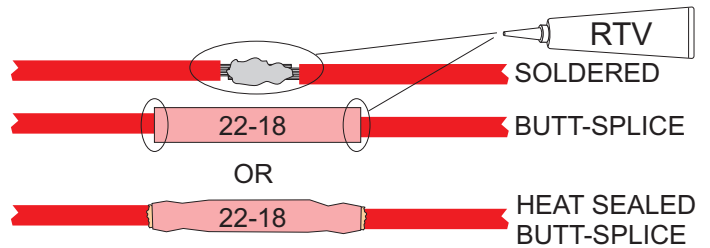

WIRING EXAMPLE

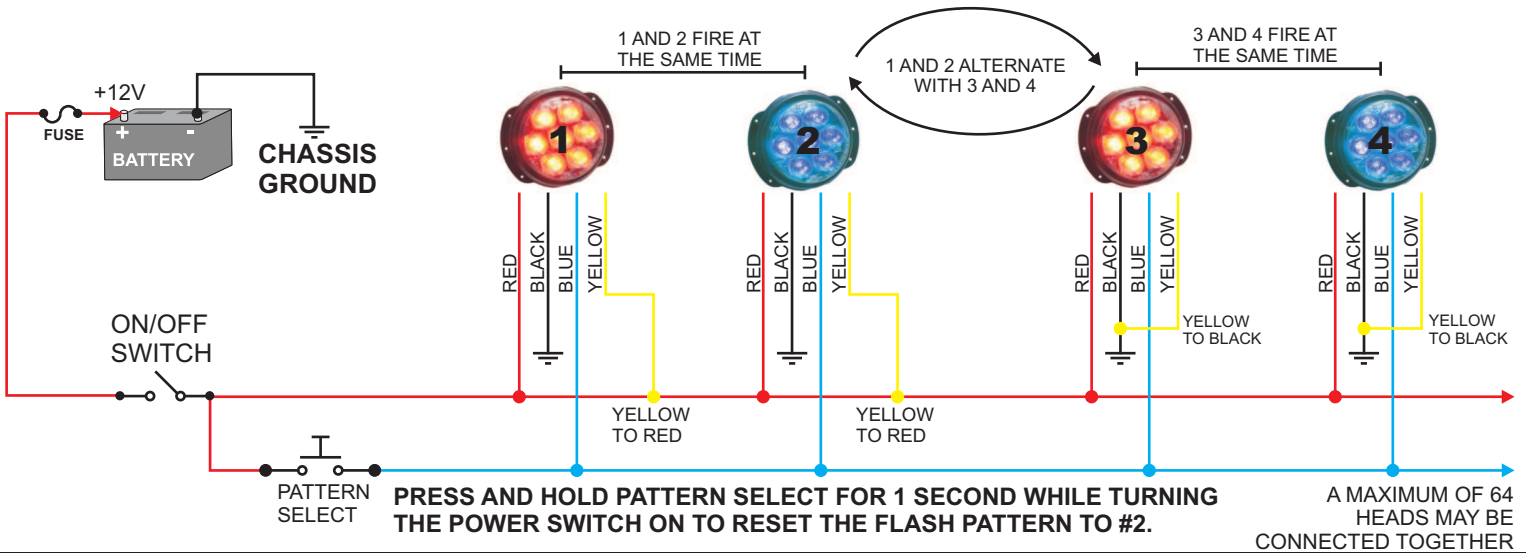

TROUBLESHOOTING

HEAD NOT FLASHING: Check the RED and BLACK wires for a reversed connection. (Reverse connection will **not** damage the unit). Check RED and BLACK wires for either a bad splice or a corroded ground connection.

HEADS NOT SYNCHRONIZING: Check for a short circuit on the BLUE wire to either +V or GROUND.

Salt water on the wire connections will short circuit the sync signal on the BLUE wire. Check for non-functional heads in the system. If any one of the heads has a bad GROUND connection it can cause the sync signal to become corrupted. If any one of the heads has its RED and BLACK wires reverse connected it will corrupt the sync signal.

FLASH PATTERN CHANGING: If the flash pattern changes on its own there may be an intermittent short between the BLUE wire and +V. Check for water in the wiring connections. If any one of the heads in the system has an intermittent GROUND connection it can also cause the flash pattern to change.