

# L36M

## INSTALLATION GUIDE



36 Doctor Foote Rd. Colchester CT 06415  
 Tel: (860) 537-3471 • Fax: (860) 537-0656  
[www.strobe.com](http://www.strobe.com)

### High-Intensity LED PAR36 Warning Signal With Center Running Light

#### TECHNICAL SPECIFICATIONS

INPUT VOLTAGE ..... 12.8V (10 to 16 Volts DC)  
 INPUT CURRENT ..... 0.65A Average, 1.25A Peak  
 LIGHT OUTPUT ..... AMBER: 276+ LUMENS  
                               BLUE: 215+ LUMENS  
                               RED: 276+ LUMENS  
                               WHITE: 770+ LUMENS  
 WIRE LENGTH ..... 1 FT  
 LED ELEMENTS ..... 7  
 FLASH PATTERNS ..... 16 (8 Standard, 8 optional cycle)  
 MAX NUMBER OF SYNC'D HEADS ..... 64  
 WARRANTY PERIOD ..... 5 YEARS

#### MOUNTING

The L36 will fit into any PAR36 size housing. Some housings require the included rubber spacer for a proper fit. Peel the paper off the adhesive backing and apply to back of L36 light head.

The L36 with rubber housing mounts using one 5/16" bolt.

The L36 with flush mount bezel will mount to any flat surface. Use the bezel as a template to mark the hole locations.

#### DIMENSIONS

#### ELECTRICAL CONNECTIONS

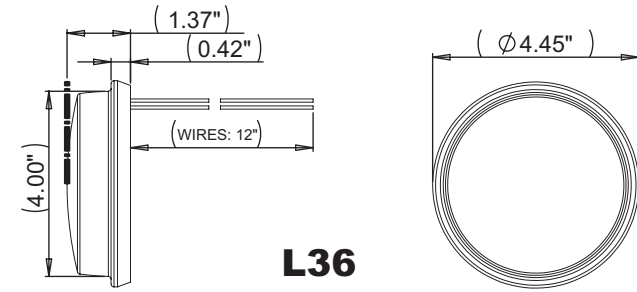

**L36**

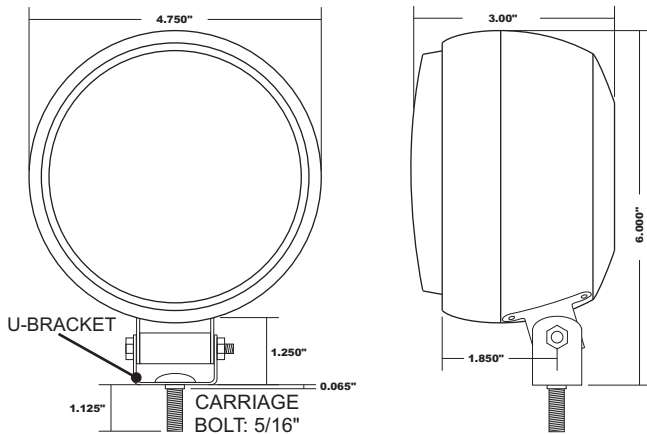

**L36 IN RUBBER HOUSING**

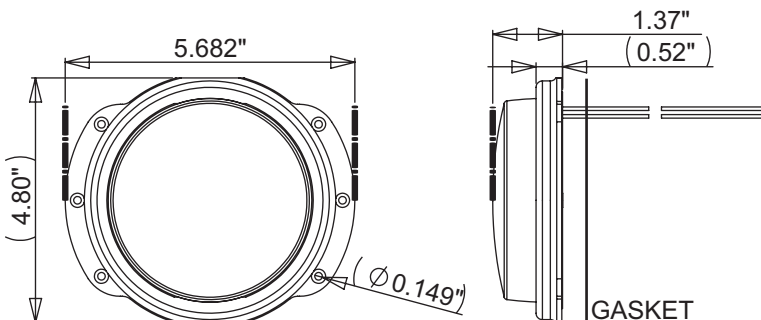

**L36 FLUSH MOUNT**

#### RED: +V

Connect RED to + Running Light connection. The use of a fuse located close to the voltage source is recommended. Size the fuse according to the number of heads used in the system. 18AWG or larger wire is recommended. When RED wire is powered the center LED will light in steady-on mode.

#### BLACK: - GROUND

Connect to - GROUND vehicle chassis. 18AWG or larger wire is recommended.



#### BLUE: Flash pattern SYNC and SELECTION wire.

If you wish to have all the LED heads synchronize their flash timings and patterns with each other then all the BLUE wires must be connected together. (64 Heads Maximum) The BLUE wire is also used to select the flash pattern. Touch the BLUE wire to +V to select the next pattern in the FLASH PATTERN LIST. The BLUE wire can also be run to a momentary push-button to allow the flash pattern to be changed when desired.

**Note: Do not connect the BLUE wire to - Ground. It will disrupt the flash pattern sync signal.**

#### YELLOW: Flash Mode

Connect to +12V through a switch to activate the flashing mode. The center LED will alternate with the outer ring of LEDs.

By default, an L36M RED-WHITE will alternate with an L36M BLUE-WHITE as shown to the right.

See the next page for instructions on changing the flash pattern and the alternating mode.

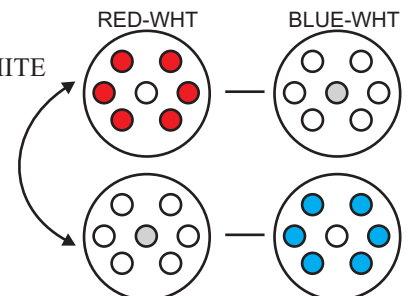

The L36 will also synchronize with any BULL LED™, HIDE-A-LED™, or SD24 head.

## FLASH PATTERNS

### POWER-UP RESET:

After installing the system it is best to do a POWER-UP RESET the first time to ensure that all heads are in sync. Touch **BLUE** wires to +V (**RED** wire) while applying power. Release **BLUE** wires. All heads will reset to Pattern #2. *If you have installed a pattern select pushbutton, press and hold pattern select while turning power switch ON.*

To select a flash pattern, touch **BLUE** to +V or press pattern select switch to increment the flash pattern. The heads will remember the selected pattern even if power is removed. All 16 flash patterns are available by default on the L36M.

STANDARD PATTERNS			
#	Pattern:	Frequency:	Description:
1	Quad Flash	1.25 Hz	75 Quad Flashes Per Minute.
2	Double Flash	1.25 Hz	75 Double Flashes Per Minute.
3	Triple Flash	1.53 Hz	92.3 Triple Flashes Per Minute.
4	DeciBlast	1.42 Hz	85.5 Deci Flashes Per Minute.
5	Single Flash	1.25 Hz	75 Single Flashes Per Minute.
6	Mega Flash	1.90 Hz	114 Single Flashes Per Minute.
7	Triple+Burst	1.37 Hz	82.5 Triple+Burst Flashes Per Minute.
8	Fast Mega	2.5 Hz	150 Single Flashes Per Minute.
CYCLE PATTERNS			
9	Cycle All		Cycle through patterns 1 to 7.
10	Double-Triple+Burst		2 Double, 2 Triple+Burst cycle.
11	Cycle Classic		1 Double, 1 Quad, 2 Mega cycle.
12	Quad-Mega		3 Quad, 4 Mega cycle.
13	Single-Quad		2 Single, 2 Quad cycle.
14	DeciBlast-Quad		2 DeciBlast, 2 Quad cycle.
15	Single-Triple-DeciBlast		2 Single, 2 Triple, 2 DeciBlast cycle.
16	Mega-Triple+Burst		1 Mega, 1 Triple+Burst cycle.

### ALTERNATING MODE:

You may change the alternating mode to make the outer rings of two heads flash at the same time as shown to the right.

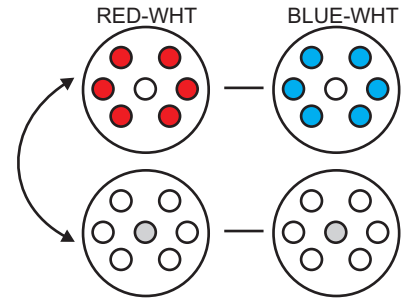

Pick only **ONE** of the L36M heads and do the following:

- 1) Touch **BLUE** wire to +V (**RED** wire) while applying power.
- 2) Hold **BLUE** wires on +V for 5 SECONDS (head will not be flashing during this time). After 5 SECONDS the head will flash the center LED once or twice to indicate the change.
- 3) Remove the **BLUE** wire from +V

The L36M will remember the mode that was selected even when removed from power. Repeat this procedure to change the alternating mode back.

## SEALING WIRE CONNECTIONS

THE WIRE CONNECTIONS MUST BE SEALED IF USED IN A WET LOCATION. WATER WILL CORRODE THE WIRES AND ALSO CAUSE SYNC PROBLEMS.

**ELECTRICAL TAPE WILL NOT SEAL A CONNECTION WE RECOMMEND AN RTV SILICONE SEALANT.**

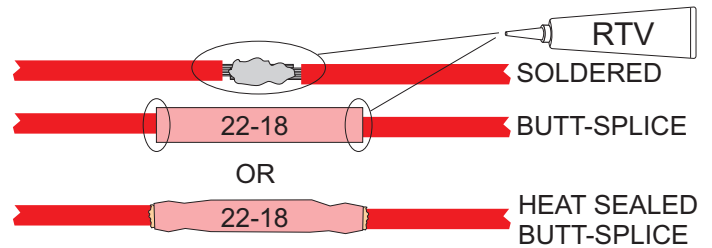

## WIRING EXAMPLE

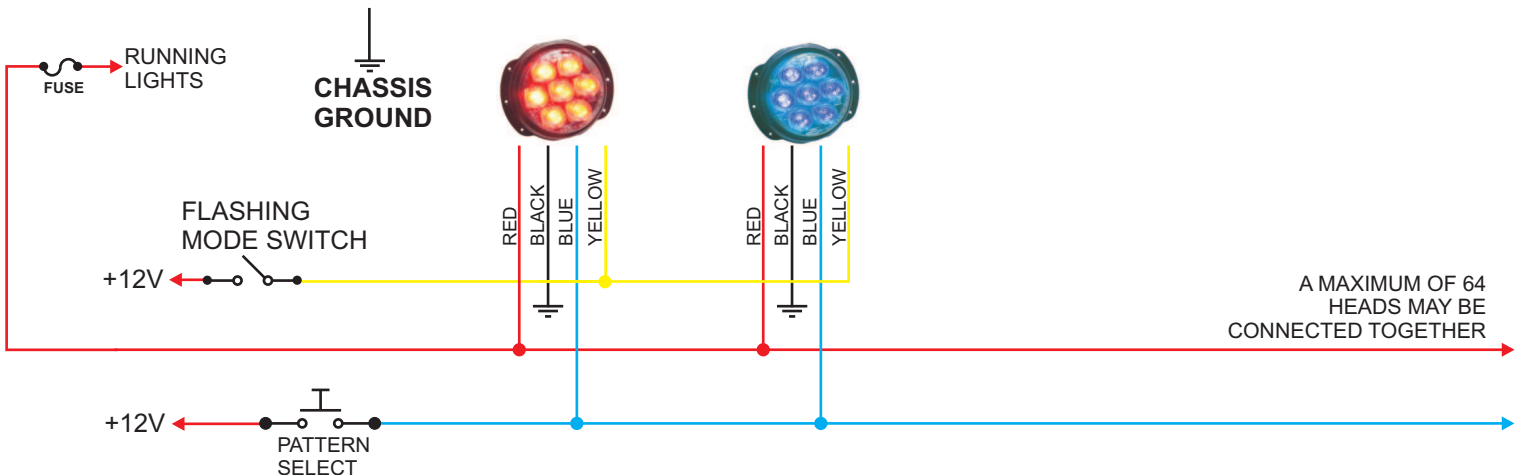

## TROUBLESHOOTING

**HEAD NOT FLASHING:** Check the RED and BLACK wires for a reversed connection. (Reverse connection will **not** damage the unit). Check RED and BLACK wires for either a bad splice or a corroded ground connection.

**HEADS NOT SYNCHRONIZING:** Check for a short circuit on the BLUE wire to either +V or GROUND.

Salt water on the wire connections will short circuit the sync signal on the BLUE wire. Check for non-functional heads in the system. If any one of the heads has a bad GROUND connection it can cause the sync signal to become corrupted. If any one of the heads has its RED and BLACK wires reverse connected it will corrupt the sync signal.

**FLASH PATTERN CHANGING:** If the flash pattern changes on its own there may be an intermittent short between the BLUE wire and +V. Check for water in the wiring connections. If any one of the heads in the system has an intermittent GROUND connection it can also cause the flash pattern to change.