

360



833 West Diamond Street • Boise, Idaho 83705
 T: (888) 844-6682 • F: (800) 688-3226 • www.strobe.com

EMERGENCY VEHICLE PRODUCTS

360 SERIES

15" Strobe Minibar Blaze® II SAE Class II

Among Nova's 15" Blaze® II low profile strobe minibar features is the advantage that it works with Nova's proven two-head power supply. Double or quad flash as well as high to low intensity light output can be user-selected at the time of installation or via a user-installed switch. All models use Nova's standard flash tube. Permanent mount installation is easy without removing dome.



Models

PART NO.	DOME	LENSES	PART NO.	DOME	LENSES
360AAA	Amber	Amber/Amber	360CBC	Clear	Blue/Clear
360ACC	Amber	Clear/Clear	360CBR	Clear	Blue/Red
360BBB	Blue	Blue/Blue	360CCC	Clear	Clear/Clear
360BCC	Blue	Clear/Clear	360CCR	Clear	Clear/Red
360CAA	Clear	Amber/Amber	360CRR	Clear	Red/Red
360CAB	Clear	Amber/Blue	360GCC	Green	Clear/Clear
360CAC	Clear	Amber/Clear	360RCC	Red	Clear/Clear
360CAR	Clear	Amber/Red	360RRR	Red	Red/Red
360CBB	Clear	Blue/Blue			

Add -VM to part # for vacuum-magnet models

Add -VM to part # for vacuum-magnet models

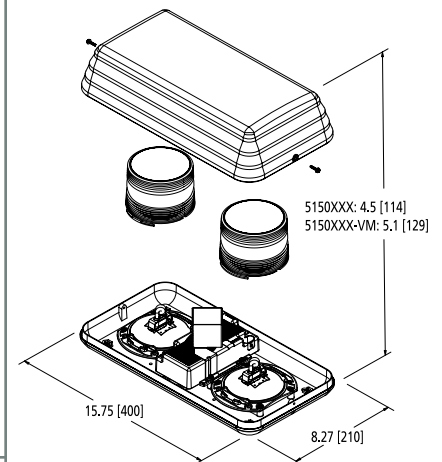

Features and Benefits

- Dual strobe lights with a fixed center mirror provide a highly visible warning signal
- Four wire leads allow user to choose double or quad flash, and high or low intensity
- Vacuum magnet models feature 15' straight cigarette cord & plug
- Polycarbonate low profile lens
- AMECA certified to SAE J1318 Class II (AAA versions only), CE, e, IP Rating 54
- 12-24 Amps, 70 Double/65 Quad FPM
- Temperature Range: -22°F to +122°F (-30°C to +50°C)
- Warranty: Minibar = 2 years, Flashtube = 6 months

Replacement Parts

- Flashtube - R6501FT
- Domes: Amber - R5100LA
 Blue - R5100LB
 Clear - R5100LC
 Red - R5100LR
- Lenses: Amber - R5150LA
 Blue - R5150LB
 Clear - R5150LC
 Red - R5150LR
- Power Supply - R9230PS