

# NB



833 West Diamond Street • Boise, Idaho 83705  
 T: (888) 844-6682 • F: (800) 688-3226 • www.strobe.com

EMERGENCY VEHICLE PRODUCTS

## NB SERIES

### Strobe Beacon SAE Class I & II

This innovative series of strobe lights combines the latest in electronic design and state-of-the-art engineering technologies. From the rugged die-cast aluminum base to the conformal coated circuit board, these strobes are built with the toughest environments in mind. No tools are needed to change the flash tube or remove the threaded O-ring sealed lens.

These lights include a jumper setting to select between double and quad flash modes, and a day night sensor to ensure the proper amount of light is being provided when it is needed.

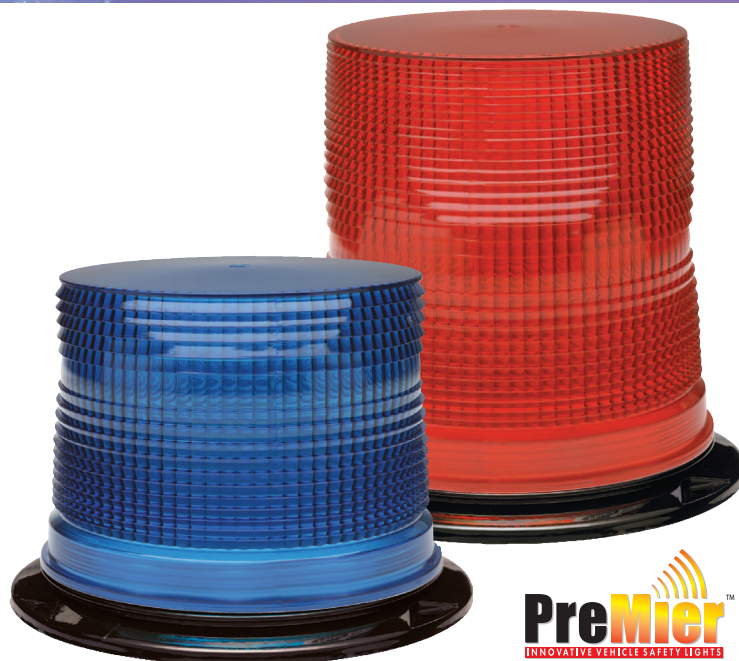

#### Models

| PART NO.                    | VDC   | LENS HEIGHT | MOUNT       | FPM                | SAE |
|-----------------------------|-------|-------------|-------------|--------------------|-----|
| NB4X                        | 12-48 | 4.6"        | Flange/Pipe | 65 Double, 65 Quad | I*  |
| Available in A, B, C, G & R |       |             |             |                    |     |
| NB4X-M                      | 12-48 | 4.6"        | Magnet      | 65 Double, 65 Quad | I*  |
| Available in A, B & G       |       |             |             |                    |     |
| NB6X                        | 12-48 | 6.4"        | Flange/Pipe | 65 Double, 65 Quad | I** |
| Available in A, B, C & R    |       |             |             |                    |     |
| NB6X-M                      | 12-48 | 6.4"        | Magnet      | 65 Double, 65 Quad | I** |
| Available in A, C & R       |       |             |             |                    |     |

Replace X in part number with desired color: A = Amber, B = Blue, C = Clear, G = Green, R = Red  
 \* NB4 Clear Lens in Quad Mode  
 \*\* NB6 Quad Mode Except Red Lens

#### Features and Benefits

- Self-adjusting for day and night
- 1½ turn Xenon flash tube plugs in, making replacement easy
- Die-cast aluminum base for vibration resistance and heat dissipation
- Conformal coated circuit board
- Meets SAE J578 June 95 and SAE J1318 May 98
- Warranty: 24 month (6 month flash tube)

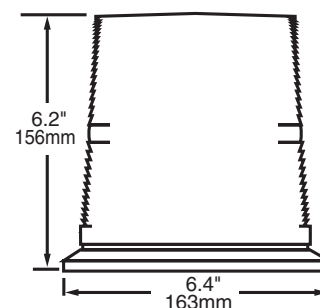
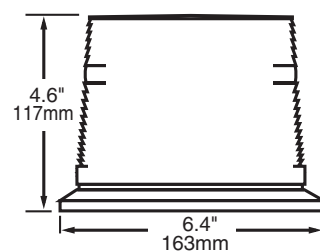

#### Replacement Parts

- Lenses: LENSNB4X, LENSNB6X
- Flash Tube: TUBENB
- Branch Guard: NB4BG, NB6BG