



Undercover Warning Signal

X1100

FEATURES:

- No central power supply required!
- Split colors
- Mounts in Horizontal and Vertical position
- 6 LEDs are Next Generation; Nova utilizes the latest technology available from the world's top LED manufacturers
- Pre-wired with a 9 foot cable
- UV stabilized polycarbonate lens
- Nickel plated housing
- Low profile mounting flange
- Only one power wire required for typical install
- Mounts in 1 inch hole
- Colors available:



Part Number	Description
X1A	Amber, X1100 Hide-A-LED
X1R	Red, X1100 Hide-A-LED
X1B	Blue, X1100 Hide-A-LED
X1G	Green, X1100 Hide-A-LED
X1W	White, X1100 Hide-A-LED

Split Colors
X1__ __ (A,B,G,R,W)

Split Colors - Three Lights in One!



FLASH PATTERNS:

		STANDARD PATTERNS			Standard Pattern Set: 8 Flash patterns that can sync with BULL LED Heads.
#	Pattern:	Frequency:	Description:		
1	Quad Flash	1.25 Hz	75 Quad Flashes Per Minute.	Standard Pattern Set: 8 Flash patterns that can sync with BULL LED Heads.	
2	Double Flash	1.25 Hz	75 Double Flashes Per Minute.		
3	Triple Flash	1.53 Hz	92.3 Triple Flashes Per Minute.		
4	DeciBlast	1.42 Hz	85.5 Deci Flashes Per Minute.		
5	Single Flash	1.25 Hz	75 Single Flashes Per Minute.		
6	Mega Flash	1.90 Hz	114 Single Flashes Per Minute.		
7	Triple+Burst	1.37 Hz	82.5 Triple+Burst Flashes Per Minute.		
8	Steady On		Steady On.		
		CYCLE PATTERNS			Extended Cycle Pattern Set: Additional 8 Flash patterns.
9	Cycle All		Cycle through patterns 1 to 7.		
10	Double-Triple+Burst		2 Double, 2 Triple+Burst cycle.		
11	Cycle Classic		1 Double, 1 Quad, 2 Mega cycle.		
12	Quad-Mega		3 Quad, 4 Mega cycle.		
13	Single-Quad		2 Single, 2 Quad cycle.		
14	DeciBlast-Quad		2 DeciBlast, 2 Quad cycle.		
15	Single-Triple-DeciBlast		2 Single, 2 Triple, 2 DeciBlast cycle.		
16	Mega-Triple+Burst		1 Mega, 1 Triple+Burst cycle.		

Delivering Safety Worldwide™

Hide-A-LED™

X1100

Integrated Heatsink

The X1100 has an Integrated Heatsink that must be used to maintain a safe operating temperature.



The Integrated Heatsink can be bent into any shape needed to fit the space available for the application.

Refer to the Installation Guide for complete instructions.

WARRANTY: 5 year factory direct

SPECIFICATIONS:

Solid Colors:

Input Voltage	10 to 30 Volts DC
Input Current	1.25 Amps @ 12.8V
	0.6 Amps @ 25.6V
Light Output	Amber: 358+ Lumens
	Blue: 240+ Lumens
	Red: 358+ Lumens
	White: 1100+ Lumens
	Green: 312+ Lumens

Split (3) Colors

Input Voltage	10 to 30 Volts DC
Input Current	0.5 Amps @ 12.8V
	0.2 Amp @ 25.6V
Light Output	Amber: 119+ Lumens
	Blue: 80+ Lumens
	Red: 119+ Lumens
	White: 367+ Lumens
	Green: 104+ Lumens

Cable Length	9 feet
LED Elements	6
Flash Patterns	16 (8 Standard, 8 Optional)
Max # of Synchronized Heads ..	64

Contents	(1) X1100 Warning Signal
	(2) Stainless Steel Screws
	(1) Gasket

BUILT-IN POWER MODULE:

- No central power supply required!
- Fits through 1 inch holes
- Waterproof circuitry

DIMENSIONS:

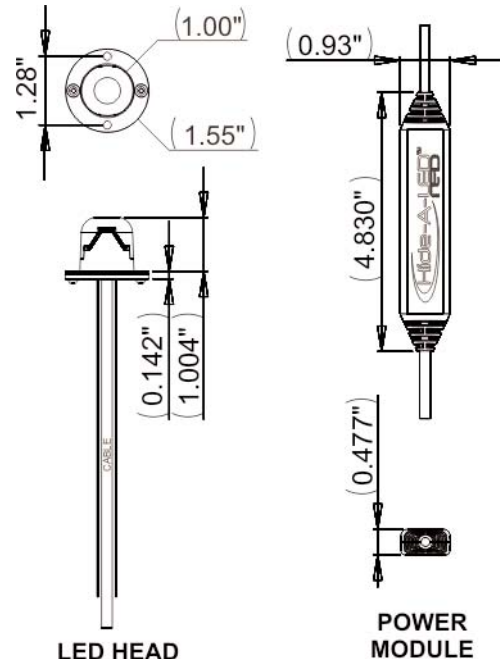

Delivering Safety Worldwide™

NOVA ELECTRONICS, INC.

860.537.3471

www.HideALED.com