

SUPERPAK 606

 **IMPORTANT!** This product is **NOT** waterproof. It must be mounted to a metal surface in a clean dry area. 

TECHNICAL SPECIFICATIONS

INPUT VOLTAGE	10 to 30 Vdc
INPUT CURRENT	5.5A at 12.8V, 2.75A at 25.6V
INPUT POWER	70.4 Watts
OUTPUT POWER	60 Watts
OUTPUT ENERGY	51.5 Joules
FLASH RATES	
Double Flash:	170 flashes per minute.
Quad Flash:	140 flashes per minute.
Quintuple Flash:	140 flashes per minute.
Mega Flash:	140 flashes per minute.

CONNECTION DIAGRAMS

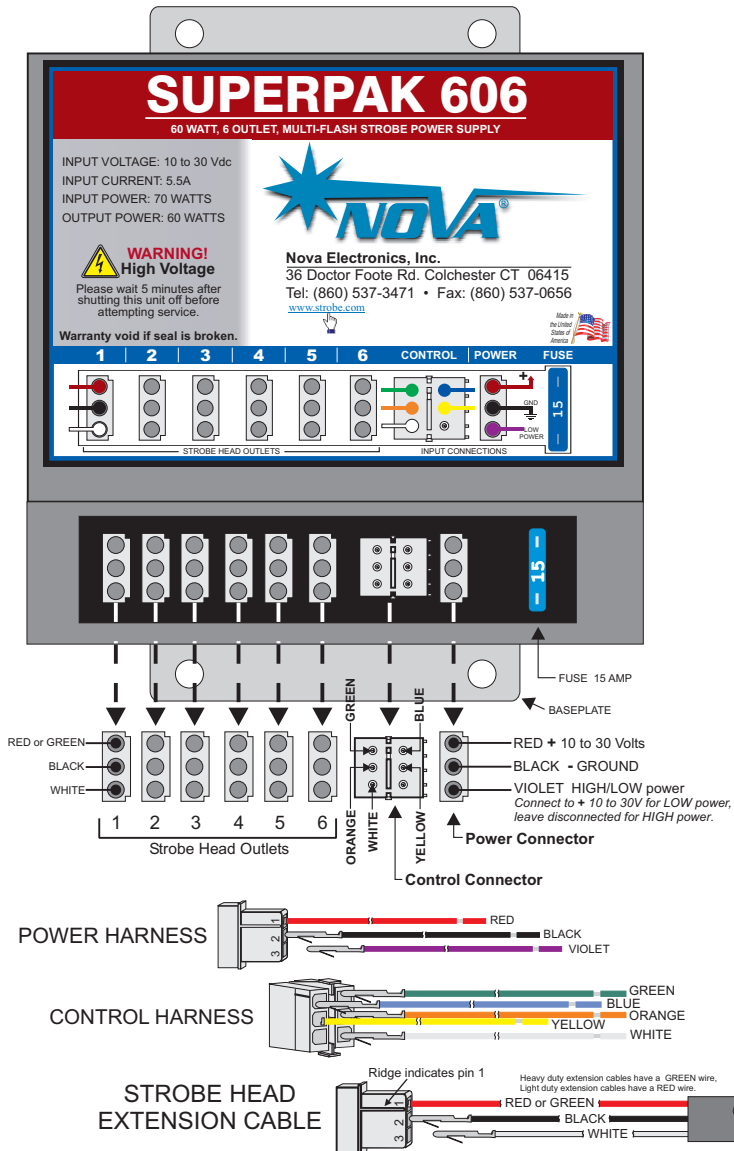

INSTALLING THE SUPERPAK 606

- Mounting Considerations**
Mount the power supply in a clean, dry location. Mounting the unit to a flat metal surface will aid in heat dissipation. Use the power supply as a template to mark the hole locations. The mounting holes will accept up to a 1/4" bolt.
Note: The power supply baseplate must be connected to chassis ground (GND) to reduce radio interference.
- Strobe Head installation**
Plug the strobe light heads into the outlets. Keep the following in mind:
 - Heads connected to outlets 1, 3, 5 flash at the same time.
 - Heads connected to outlets 2, 4, 6 flash at the same time.
 - Heads connected to 1, 3, 5 alternate with heads 2, 4, 6.
- Electrical Hookup**
If you have purchased a pre wired switch harness, follow the included instructions. If you are wiring the system yourself follow the instructions below and the diagrams on the next page.

POWER HARNESS:

- Connect the RED wire to battery positive (+) or a fuse panel circuit rated for at least 15 AMPS.
- Connect the BLACK wire to battery negative (-) or directly to vehicle chassis.

Note: Use the correct size wire for power connections. The length of the wires determines the size needed.

- 1 to 10 ft. use 18AWG wire.
- 10 to 20 ft. use 16AWG wire.
- 20 to 35 ft. use 14AWG wire.
- 35 to 50 ft. use 12AWG wire.

- The VIOLET wire controls HIGH / LOW power. Low power limits the flash intensity for nighttime use. Connect VIOLET to +12/24V for LOW power, leave VIOLET disconnected for HIGH power.

CONTROL HARNESS:

BLUE: Enables Heads 1 & 2 when connected to +12/24V
 GREEN: Enables Heads 3 & 4 when connected to +12/24V
 YELLOW: Enables Heads 5 & 6 when connected to +12/24V.
 WHITE + ORANGE: Selects the Flash Pattern as follows:

WIRED TO +12/24V	FLASH PATTERN
NONE	Quad Flash
ORANGE	Mega Flash
WHITE	Quintuple Flash
WHITE + ORANGE	Double Flash

Note: VIOLET, YELLOW, GREEN, BLUE, WHITE, and ORANGE are all Low Current circuits and can be wired with a minimum of 22AWG wire.

WIRING/CONNECTION DIAGRAMS

DIAGRAM (1): ON/OFF and Low Power using two toggle switches. Choose flash pattern from chart.

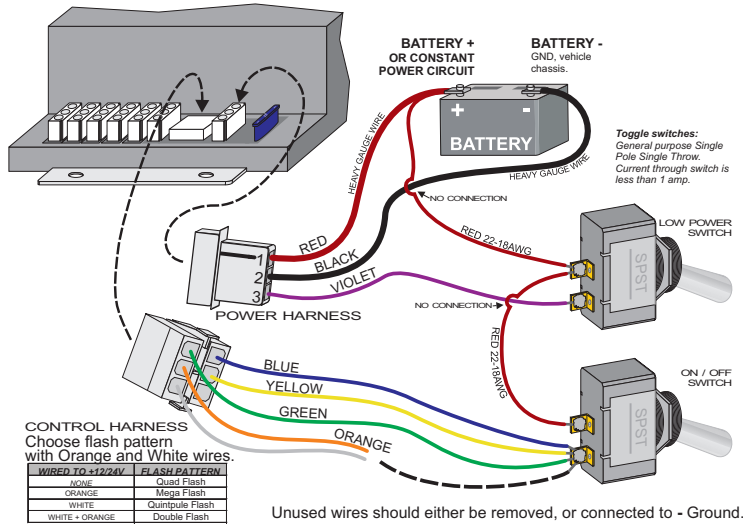

DIAGRAM (2): ON/OFF and Low Power using one DPDT rocker switch. Choose flash pattern from chart.

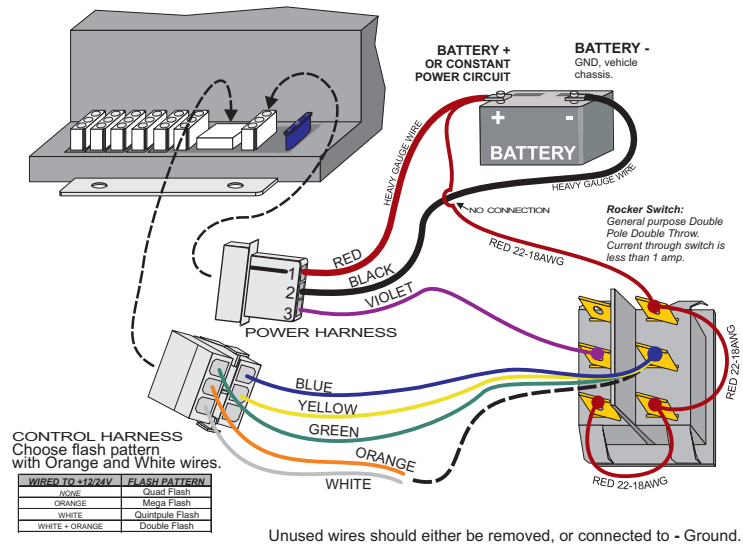
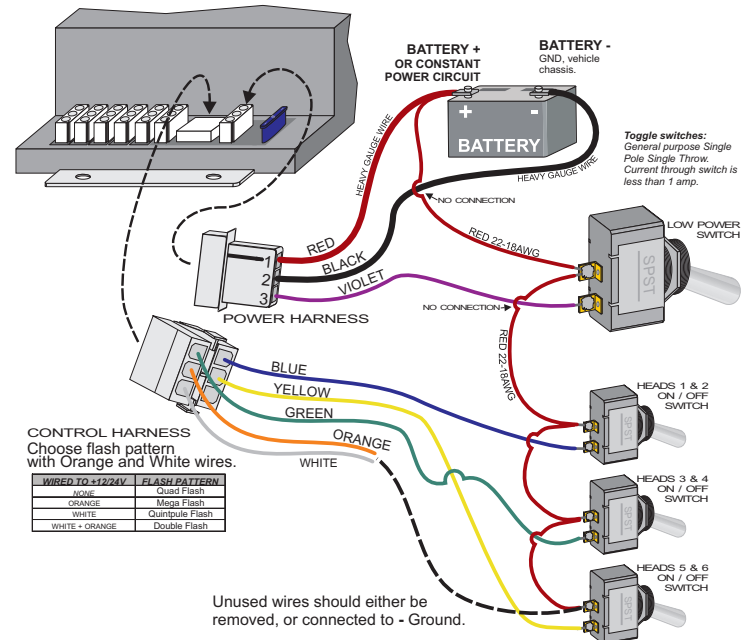

DIAGRAM (3): Selective switching of strobe head pairs. Low Power selection. Choose flash pattern from chart.



PATTERN TABLE

Selecting a flash pattern: In the table below, find the desired flash pattern. Connect the wires marked **POWER** to the 'load' side of the ON/OFF switch. Remove the remaining wires, or connect them to - Ground.

Example: To use pattern #8 (Quad Flash, All Heads), connect the YELLOW, GREEN and BLUE wires to POWER. Remove the remaining wires, or connect them to - Ground.

PATTERN	WHITE	ORANGE	YELLOW	GREEN	BLUE	FUNCTION
1						SHUTDOWN
2					POWER	Quad Flash, 1 Alt 2
3				POWER		Quad Flash, 3 Alt 4
4				POWER	POWER	Quad Flash, 1+3 Alt 2+4
5			POWER			Quad Flash, 5 Alt 6
6			POWER		POWER	Quad Flash, 1+5 Alt 2+6
7			POWER	POWER		Quad Flash, 3+5 Alt 4+6
8			POWER	POWER	POWER	Quad Flash, 1+3+5 Alt 2+4+6
9		POWER				SHUTDOWN
10		POWER			POWER	Mega Flash, 1 Alt 2
11		POWER		POWER		Mega Flash, 3 Alt 4
12		POWER		POWER	POWER	Mega Flash, 1+3 Alt 2+4
13		POWER	POWER			Mega Flash, 5 Alt 6
14		POWER	POWER		POWER	Mega Flash, 1+5 Alt 2+6
15		POWER	POWER	POWER		Mega Flash, 3+5 Alt 4+6
16		POWER	POWER	POWER	POWER	Mega Flash, 1+3+5 Alt 2+4+6
17	POWER					SHUTDOWN
18	POWER				POWER	Quintuple Flash, 1 Alt 2
19	POWER			POWER		Quintuple Flash, 3 Alt 4
20	POWER			POWER	POWER	Quintuple Flash, 1+3 Alt 2+4
21	POWER		POWER			Quintuple Flash, 5 Alt 6
22	POWER		POWER		POWER	Quintuple Flash, 1+5 Alt 2+6
23	POWER		POWER	POWER		Quintuple Flash, 3+5 Alt 4+6
24	POWER		POWER	POWER	POWER	Quintuple Flash, 1+3+5 Alt 2+4+6
25	POWER	POWER				SHUTDOWN
26	POWER	POWER			POWER	Double Flash, 1 Alt 2
27	POWER	POWER		POWER		Double Flash, 3 Alt 4
28	POWER	POWER		POWER	POWER	Double Flash, 1+3 Alt 2+4
29	POWER	POWER	POWER		POWER	Double Flash, 5 Alt 6
30	POWER	POWER	POWER		POWER	Double Flash, 1+5 Alt 2+6
31	POWER	POWER	POWER	POWER		Double Flash, 3+5 Alt 4+6
32	POWER	POWER	POWER	POWER	POWER	Double Flash, 1+3+5 Alt 2+4+6

Alt = 'Alternates with'

TROUBLESHOOTING

Blown Fuse: The SUPERPAK 606 will blow a fuse if the input voltage is reversed. If this happens, first locate the wiring fault, then replace the fuse with one of the same rating.

Erratic behavior (and/or) shutdown: The SUPERPAK 606 will shut down if there is a short circuit condition on any one of the strobe heads. If the electrical conductors connecting the power supply to the strobe heads are exposed to water a short circuit will result. The first sign is intermittent operation, followed by complete shutdown of the strobe system. To find the short circuit, unplug all strobe head cables from the SUPERPAK 606. Test **one** cable/head at a time until the problem is found.

ACCESSORIES

The following accessories are available to make the installation of the SUPERPAK 606 power supply even easier:

ROTARY SWITCH PANEL

A fully assembled switch panel which provides full selection of all flash patterns as well as On/Off and Low Power control.

All panels are pre-wired with 15'(standard) of cabling.