



# XPAK604X

## 60 WATT 4 OUTLET STROBE POWER SUPPLY

 **IMPORTANT!** This product is **NOT** waterproof. It must be mounted in a clean, dry location. 

### TECHNICAL SPECIFICATIONS

INPUT VOLTAGE .....	10 to 30 Vdc
INPUT CURRENT .....	5.5A at 12.8V, 2.6A at 25.6V
INPUT POWER .....	70.4 Watts
OUTPUT POWER .....	60 Watts in high power mode.
	40 Watts in low power mode.
OUTPUT ENERGY .....	51.5 Joules
FLASH PATTERNS.....	15

### QUICK REFERENCE

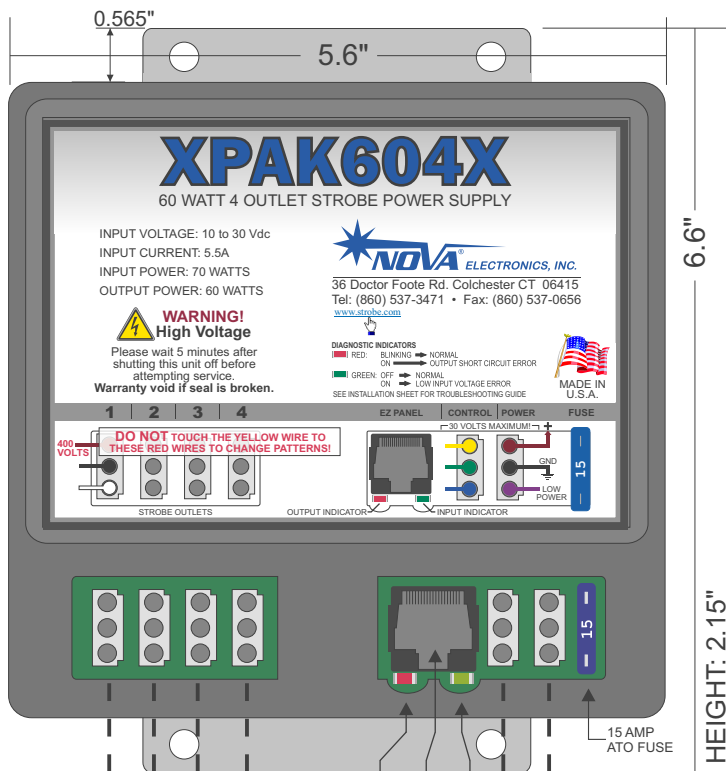

### INSTALLATION

- Mounting:**  
If possible, mount to a flat metal surface to aid in heat dissipation. Mount in a clean, **dry** area. **NEVER MOUNT IN ENGINE COMPARTMENT!** Use the power supply as a template to mark the hole locations. The mounting holes will accept up to a 1/4" bolt.  
*Note: The power supply baseplate must be connected to chassis ground (GND) to reduce radio interference.*
- Strobe Head Installation:**  
Plug the strobe head extension cables into the outlets.
  - Heads connected to outlets 1 and 3 flash at the same time.
  - Heads connected to outlets 2 and 4 flash at the same time.
  - Heads connected to 1 and 3 alternate with heads 2 and 4.
  - Be sure to use strobe heads with the correct power rating.
 The total output power (60 Watts) of the XPAK604X is distributed to the strobe heads as follows:
  - 1 Head installed and activated = 30 Watts.
  - 2 Heads installed and/or activated = 30 Watts per head.
  - 3 Heads installed and/or activated = 2 heads at 15 Watts each, 1 at 30 Watts.
  - 4 Heads installed and/or activated = 15 Watts per head.
- Electrical Hookup:**  
If you have purchased a switch panel, follow the included instructions. If you are wiring the system yourself follow the instructions below and the diagrams on the next page.

#### POWER HARNESS:

- Connect the **RED** wire to BATTERY + through a 15A fuse (customer supplied) located at the battery.
  - Connect the **BLACK** wire to battery negative (-) or directly to vehicle chassis.
- Note: Use the correct size wire for power connections. The length of the wires determines the size needed.*
- 1 to 10 ft. use 18AWG wire.
  - 10 to 20 ft. use 16AWG wire.
  - 20 to 35 ft. use 14AWG wire.
  - 35 to 50 ft. use 12AWG wire.

- The **VIOLET** wire activates LOW power mode. The output power is reduced to 40 Watts in LOW power mode. Connect **VIOLET** to +12/24V to activate LOW power mode, leave disconnected or connect to GROUND for high power mode.

#### CONTROL HARNESS: **DO NOT CONNECT ANY OF THESE WIRES TO THE HIGH VOLTAGE STROBE OUTLETS!!!**

- YELLOW:** Flash pattern selection. Momentarily connect to +12/24V to advance to the next flash pattern in the PATTERN LIST. Momentarily connect for 3 seconds to reset to pattern #1. The flash pattern will be retained when the XPAK604X is turned off or if power is removed. To change flash patterns frequently, connect **YELLOW** to a momentary pushbutton located in the passenger compartment.
- GREEN:** Activates Heads 1 and 2 when connected to +12/24V.
- BLUE:** Activates Heads 3 and 4 when connected to +12/24V.

**NOTE:** VIOLET, YELLOW, GREEN, and BLUE are all **Low Current** circuits and can be wired with a minimum of 18AWG wire.

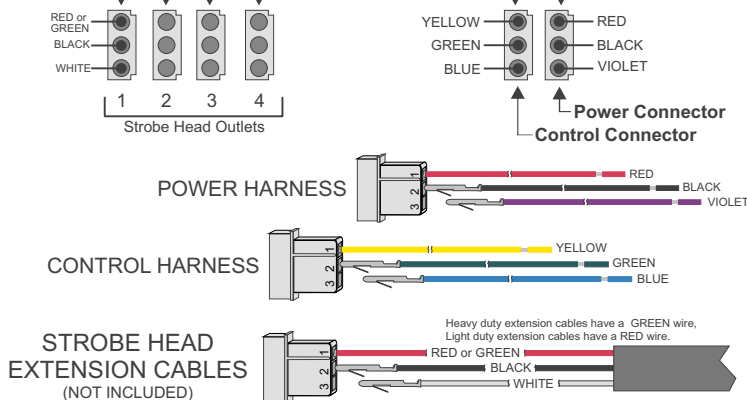

## WIRING DIAGRAM 1

ON/OFF and LOW POWER control.

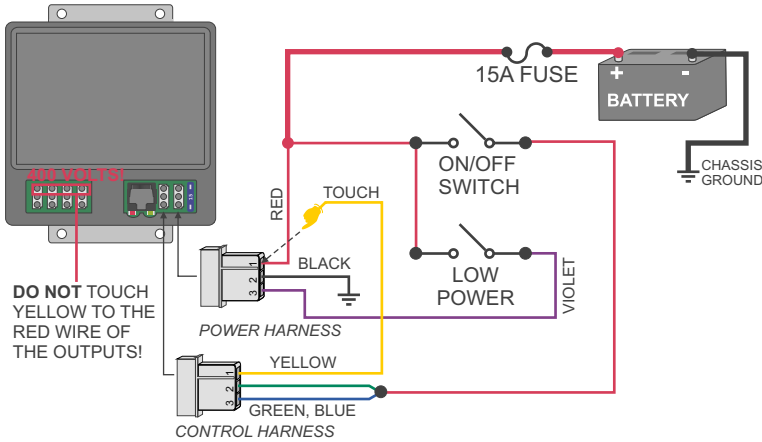

DO NOT TOUCH YELLOW TO THE RED WIRE OF THE OUTPUTS!

Touch YELLOW to the terminal of the RED wire to select flash pattern. Connect YELLOW to GROUND to ensure that flash pattern will never change.

## WIRING DIAGRAM 2

ON/OFF and PATTERN SELECT switches. High Power mode.

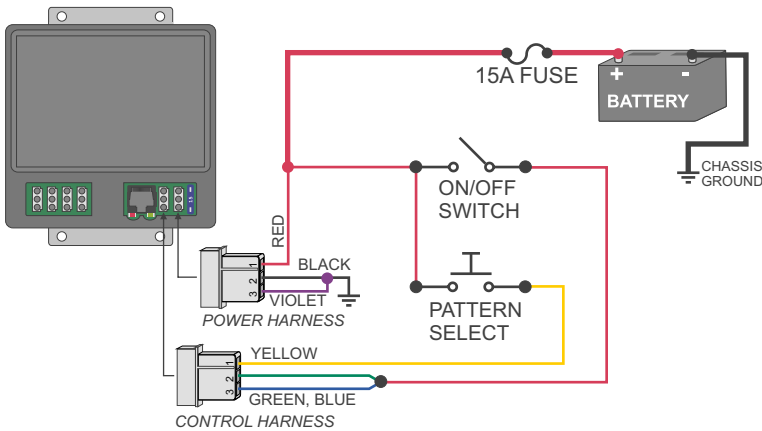

## WIRING DIAGRAM 3

SELECTIVE HEAD SWITCHING and PATTERN SELECT. High Power mode.

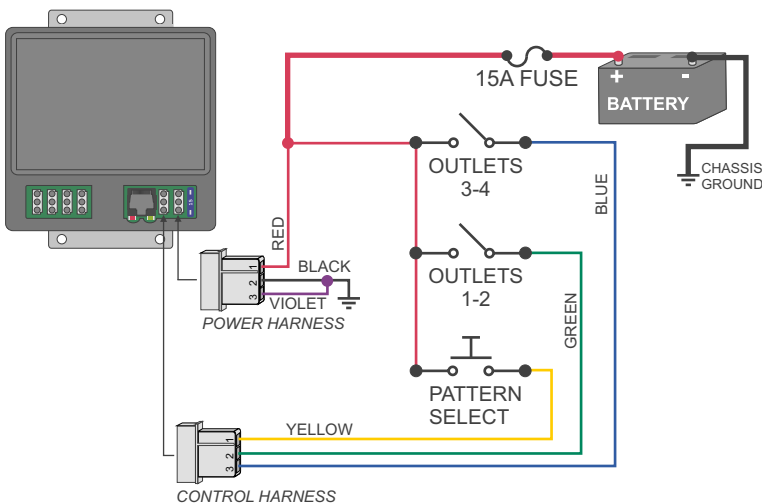

## EZ PANEL CONNECTOR



- The EZ PANEL connector is only for use with the EZ PANEL series of control panels.
- Do not connect both the EZ PANEL cable and the standard control wires at the same time!
- Do not connect any other devices to the EZ PANEL connector as permanent damage may result.
- Use only approved cables with the EZ PANEL.

## FLASH PATTERN SELECTION

Momentarily connect YELLOW wire to +12/24V to advance to the next flash pattern in the list below. (Or use pushbutton if you installed one). The flash pattern loops back to pattern #1 when it is advanced past #15. If you are unsure of which flash pattern is currently selected, connect and hold YELLOW to +12/24V for 3 seconds to reset to flash pattern #1.

#	Flash Pattern	Description
1	Quad Flash	4 Flash bursts alternating, 140 Quad Flashes Per Minute.
2	Quintuple Flash	5 Flash bursts alternating, 140 Quintuple Flashes Per Minute.
3	Mega Flash	1 Flash burst alternating, 700 Flashes Per Minute.
4	Double Flash	2 Flash bursts alternating, 125 Double Flashes Per Minute.
5	Single Flash	1 Flash burst alternating, 200 Single Flashes Per Minute.
6	Twin Single Flash	Two Single Flash bursts before alternating, 120 Twin Single Flashes Per Minute.
7	Twin Double Flash	Two Double Flash bursts before alternating, 100 Twin Single Flashes Per Minute.
8	Triple Flash	3 Flash bursts alternating, 140 Triple Flashes Per Minute.
9	Twin Triple Flash	Two Triple Flash bursts before alternating, 70 Twin Triple Flashes Per Minute.
10	Twin Mega Flash	Two Mega flash bursts before alternating, 350 Twin Mega! Flashes Per Minute
11	Triple-Mega-Bang	Three Flashes alternating then one Single Flash. 76 Flashes Per Minute.
12	Warble	6 Single flashes alternating at 450 FPM, 6 single flashes alternating at 860 FPM.
13	Phased Mega Flash	1 Flash burst alternating, Flash rate varies from 360 FPM to 860 FPM
14	Single-Quad	Single Flash - Quad Flash combination pattern.
15	Cycle Flash	Two warble flashes, Two Quad Flashes, Two Mega Flashes in a continuous cycle.

## TROUBLESHOOTING

### DIAGNOSTIC INDICATORS

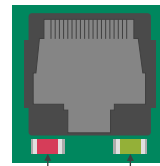

The XPAK604X is equipped with two diagnostic indicators located on the PC board directly below the EZ PANEL connector. If the XPAK604X has stopped functioning check the diagnostic lights and follow the instructions below.

### OUTPUT INDICATOR (RED)

**NORMAL:** The OUTPUT INDICATOR will light when ANY strobe head fires. It will blink in exact time with the flash pattern. When the XPAK604X is turned off the indicator may dimly blink for a few seconds. This indicates that the power supply is discharging itself.

**PROBLEM:** If the XPAK604X is activated but none of the strobe heads are firing, check the OUTPUT INDICATOR. If the light is blinking or on steady then it indicates that there is a short circuit on one or more of the strobe head outputs.

To find the short circuit, unplug **all** strobe head cables from the XPAK604X. Test **one** cable/head at a time until the problem is found.

**Do not test with more than one cable/head installed.**

The problem is typically at the strobe head end of the cable. If there is a blue/green or black colored corrosion on the connector it is shorted. *Also check for a head or cable with a reverse wired connector.*

### INPUT INDICATOR (GREEN)

**NORMAL:** The INPUT INDICATOR should **NOT** be lit during normal operation. It may blink for a second when power is first applied to the XPAK604X, or when power is removed but this does not indicate a problem with the power supply.

**PROBLEM:** If the XPAK604X is activated but none of the strobe heads are firing, check the INPUT INDICATOR. If it is ON then it indicates that the input voltage is too low (below 10V).

There may be a bad connection to the battery or ground.

If the XPAK604X is functioning but the INPUT INDICATOR is blinking or lit it indicates that the voltage is too low and the power supply is not operating at full power. Check for bad connections and be sure the proper size wire was used for the + and - connections.

### — 15 — BLOWN FUSE

The XPAK604X will blow a fuse if the input voltage is reversed. If this happens, first locate the wiring fault, then replace the fuse with one of the same rating. If the fuse continues to blow it indicates an internal fault. Do not use a fuse larger than 15A!