

LEDFLASHER1

12 VOLT LED HEAD FLASHER

TECHNICAL SPECIFICATIONS

INPUT VOLTAGE	12.8 Volts DC.
OUTPUT VOLTAGE	12.8 Volts DC.
NUMBER OF OUTPUTS.....	2 Alternating.
AMPERAGE RATING	10 Amps per output wire.
FLASH PATTERNS.....	12
FLASH RATES.....	1.3 FPS up to 1200 FPM

DIMENSIONS

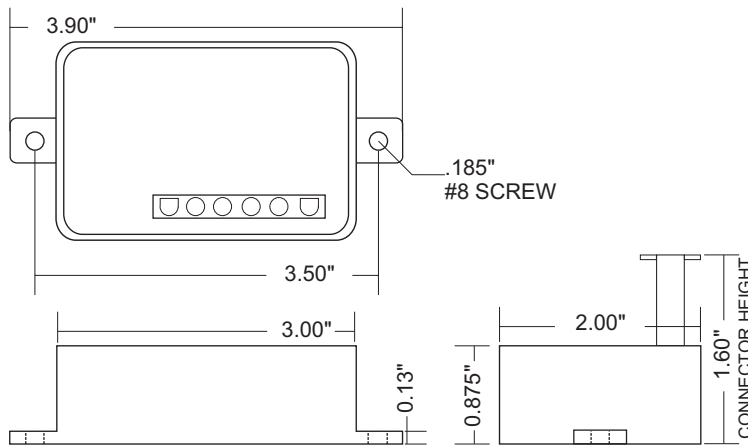

WIRING HARNESS

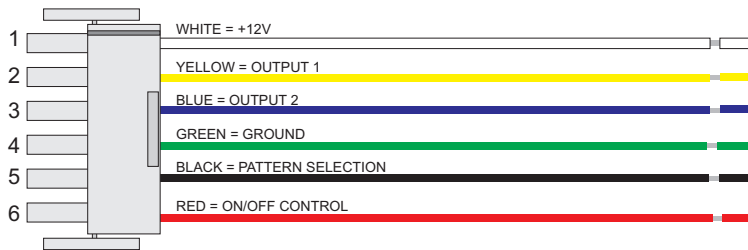

INTRODUCTION

The LEDFLASHER1 is designed to flash **12 Volt** LED heads. Halogen or Incandescent bulbs may also be used, however the faster flash patterns will not function correctly due to the long turn-on time of standard lamps.

The LEDFLASHER1 was not intended to flash any of the factory installed lamps or bulbs on a vehicle. Modern automobiles use indicator lamp wiring to carry control signals to other critical systems such as the transmission. Flashers which directly control the vehicle's existing lamps can interfere with these signals and cause severe problems.

We do not recommend altering the factory vehicle wiring!

INSTALLING THE FLASHER

1) **Mounting:**
The LEDFLASHER1 is completely weatherproof and can be safely mounted in the engine compartment. The LEDFLASHER1 can be mounted to any flat surface with two #6 or #8 screws.

2) **Electrical Connections:**
Note: We recommend using a corrosion preventative compound on the connector pins of the LEDFLASHER1. Use **only** compounds specifically designed for electrical contacts and switches, such as Truck-lite® NYK Corrosion Preventive Compound.

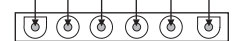

Connect the supplied 6 wire harness as follows:

WHITE: Connect through a 25 AMP fuse to Battery (+). The following chart shows the size of wire to use:

Distance From Battery:	Recommended Wire Size:
1 to 10 Feet	16 AWG
10 to 15 Feet	14 AWG
15 to 25 Feet	12 AWG
25 to 40 Feet	10 AWG

GREEN: Connect to chassis GND or Battery (-).

BLUE, YELLOW: (OUTPUT WIRES)

Connect to the +12V terminals of the LED HEADS. Connect negative leads of LED heads to chassis ground. **Note:** When flashing a pattern, BLUE always alternates with YELLOW. Each wire can supply up to 10 AMPS of current to the light heads.

RED: On/Off Control. Flasher is ON when RED is connected to +12 Volts, OFF when disconnected. This is a low current connection and can be run with as small as 22AWG wire.

3) **Test the System:**
When all of the above connections are made, plug the wiring harness into the LEDFLASHER1 and turn the on/off switch to on (connect RED to +12V). The flasher will start in Random Level 4 mode.

If you wish to change the **FLASH PATTERN**, turn the flasher ON and simply touch the **BLACK** wire to +12V momentarily. The flash pattern will change to the next number in the FLASH PATTERN TABLE (next page). Each time you touch the **BLACK** wire to +12V, the flash pattern will increment. If you go past Pattern #7 it will cycle back around to Pattern #1. *Continued on next page...*

CHANGING FLASH PATTERN

...Continued from previous page.

The LEDFLASHER1 remembers the flash pattern which you select. The next time you turn the flasher on, it will start that flash pattern automatically. The flasher will store this selection even if it is disconnected from the vehicle, or the vehicle loses power.

When you have selected the flash pattern that you wish to use, simply wrap the end of the **BLACK** wire with

electrical tape. You can change the flash pattern again at any time by using the **BLACK** wire as described. You can select flash patterns as many times as you wish.

Optionally, you may connect **BLACK** to a momentary pushbutton switch. Connect the other terminal of the switch to +12V. The flash pattern will increment each time the

FLASH PATTERN TABLE		
#	Flash Pattern	Description
1	Random Level 4	Randomly selects from patterns 5 through 12 and runs each pattern 4 times.
2	Steady On	Turns both outputs on. No Flashing.
3	Random Level 10	Randomly selects from patterns 5 through 12 and runs each pattern 10 times.
4	Flasher	Wig-Wag Flasher pattern 1.3 Flashes per second rate.
5	Double Flash	2 Flash Bursts. 115 Double Flashes Per Minute.
6	Quad Flash	4 Flash Bursts. 140 Quad Flashes Per Minute.
7	Quintuple Flash	5 Flash Bursts. 150 Quintuple Flashes Per Minute.
8	Mega Flash	1 Flash Burst. 500 Flashes Per Minute.
9	Octa Flash	8 Flash Bursts. 150 Octa Flashes Per Minute.
10	Phased Mega	1 Flash Burst. Varies from 360 to 1200 Flashes Per Minute.
11	DeciBlast	10 Flash Bursts. 170 Deci Flashes Per Minute.
12	Warble	1 Flash Burst. Varies from 250 to 500 Flashes Per Minute.

WIRING DIAGRAM

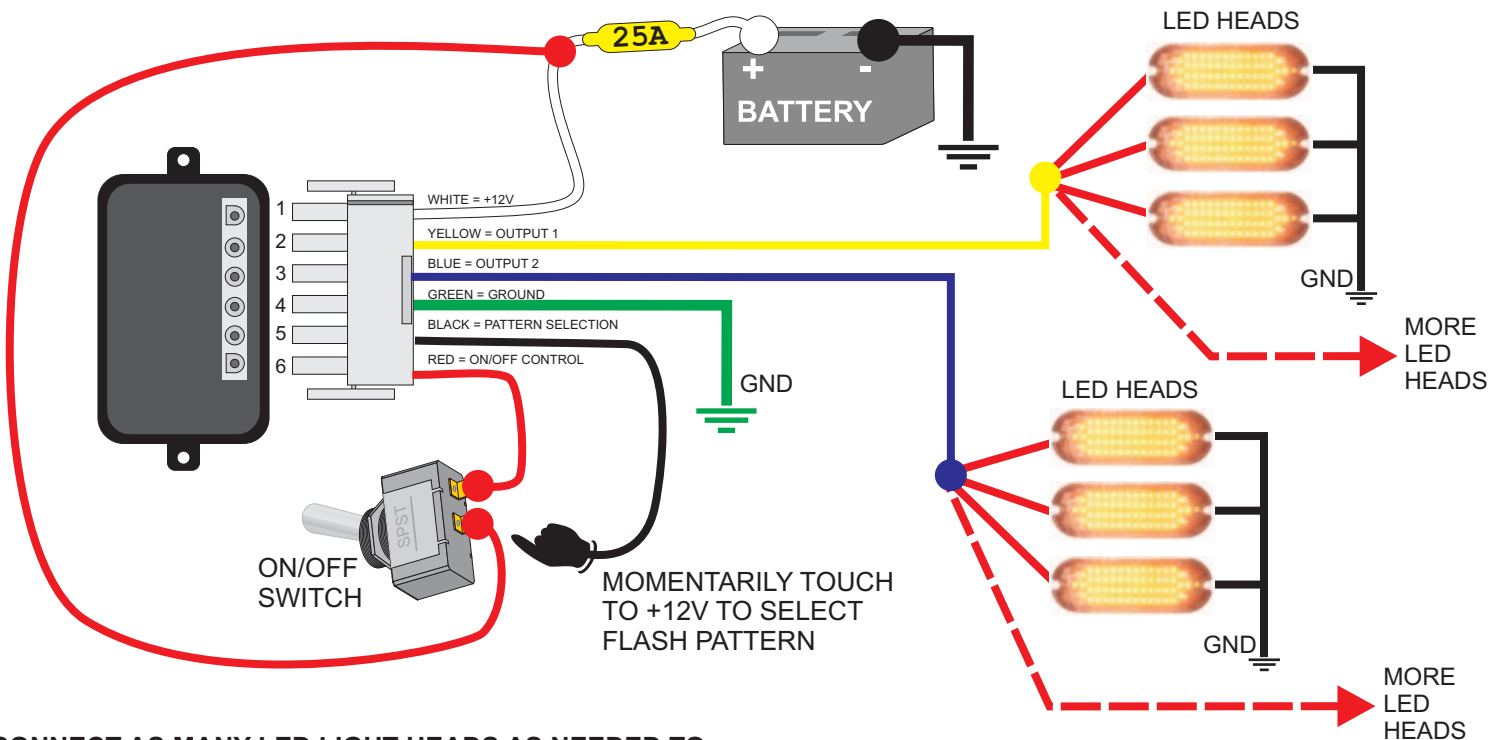

CONNECT AS MANY LED LIGHT HEADS AS NEEDED TO EACH OF THE OUTPUT WIRES. DO NOT EXCEED THE MAXIMUM CURRENT RATING OF THE OUTPUT WIRES (10A).

MAXIMUM NUMBER OF NOVA SMT SERIES LED HEADS PER OUTPUT WIRE.

LED HEADS PER OUTPUT:	LED HEAD CURRENT DRAW:	TOTAL CURRENT PER OUTPUT WIRE:	PRODUCTS:
12	0.8 AMPS	9.6 AMPS	LEDWIC3, LEDWIC3RND, LEDWIC35, SLWIC3, SLWIC3RND, SLWIC35
20	0.5 AMPS	10 AMPS	SLMINI, SLULTRA