

INTELLIPAK 2

2 OUTLET LUMIBLAST SERIES 2 POWER SUPPLY



TECHNICAL SPECIFICATIONS

INPUT VOLTAGE:	10 to 16 Vdc.
INPUT CURRENT:	
MAXIMUM	0.5A
INPUT CURRENT (STANDBY MODE):	0.005A
OUTPUT VOLTAGE:	2 to 28 Vdc.
OUTPUT CURRENT:	350ma Constant Current Regulated.
OPERATING TEMPERATURE:	-40C to +55C

DIMENSIONS

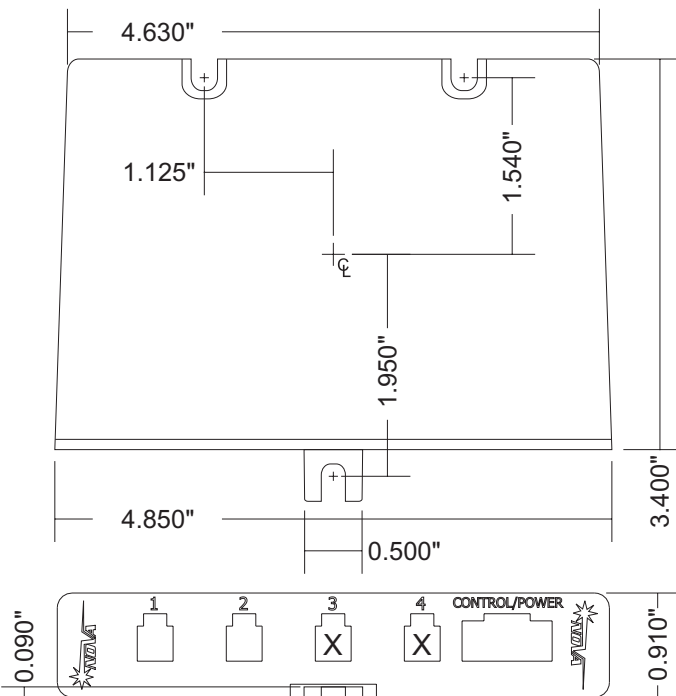

CONTROL/POWER HARNESS

(1) CONTROL/POWER HARNESS INCLUDED

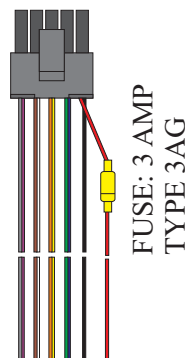
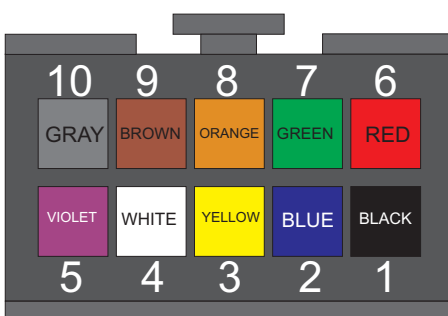

INSTALLING THE INTELLIPAK

1. Mounting

The INTELLIPAK can be mounted to a flat surface using either the three screws or Velcro dots provided. *If the INTELLIPAK is to be mounted in a damp location we recommend using a corrosion preventative on the electrical connections. Use **only** compounds specifically designed for electrical contacts and switches, such as Truck-lite® NYK Corrosion Preventive Compound.*

2. LED Light Heads:



USE ONLY LUMIBLAST SERIES 1 OR 2 LED HEADS ON THIS POWER SUPPLY



The INTELLIPAK is a *Constant Current Power Supply* designed to drive the LUMIBLAST SERIES 1 and 2 LED heads only. **If the LED Head does not have the LUMIBLAST SERIES 1 or 2 logo do not connect it to the INTELLIPAK!**

LED heads from other manufacturers ARE NOT compatible with the INTELLIPAK!

This power supply automatically adjusts the VOLTAGE of each output so that exactly 350 milliamps of CURRENT flows through the LED head. This ensures consistent light output regardless of any changes in head temperature or battery voltage.

LED Head Installation:

Mount the LumiBlast LED Heads in the desired locations, route the LumiBlast LED cables through the vehicle and plug into outlet connectors labeled 1-2. Outlets 1-2 are activated by the GREEN wire.

(Outlet connectors 3-4 not present on 2 outlet version)

The INTELLIPAK has an independent driver for each outlet. Light intensity is not affected by the number of heads installed or activated.

3. Electrical Hookup

If you have purchased a pre wired switch harness, follow the included instructions. If you are wiring the system yourself follow the instructions and diagrams on the next page.

ELECTRICAL HOOKUP

CONTROL/POWER HARNESS:

RED WIRE:

Connect the RED wire to battery positive (+) or a fuse panel circuit rated for at least 5A. We recommend connecting this to a constant powered circuit. 20AWG minimum wire size.

BLACK WIRE:

Connect the BLACK wire to battery negative (-) or directly to vehicle chassis. 20AWG minimum wire size.

GREEN WIRE:

Activates outlets 1 and 2 when connected to +12V.

BLUE WIRE:

No function on 2 outlet version.

BROWN, WHITE, ORANGE, YELLOW:

Select Flash Pattern: Connect to +12V in combinations shown in the Flash Pattern Table.

VIOLET, GREY:

No function (Future expansion).

Remove or connect to (-) GND.

RPM TECHNOLOGY

The INTELLIPAK contains Random Pattern and Mapping technology. This section will help you to understand this technology and explain the terms used.



Flash Patterns # 13-16 are RPM patterns. Random Pattern selection randomly selects from patterns #1-11. *Random Level* is the number of times a pattern will repeat before a new pattern is randomly chosen. (2 or 4)

Note: The functions Head Mapping and CHAOS Mode are not possible on the INTELLIPAK 2 outlet version.

WIRING DIAGRAM

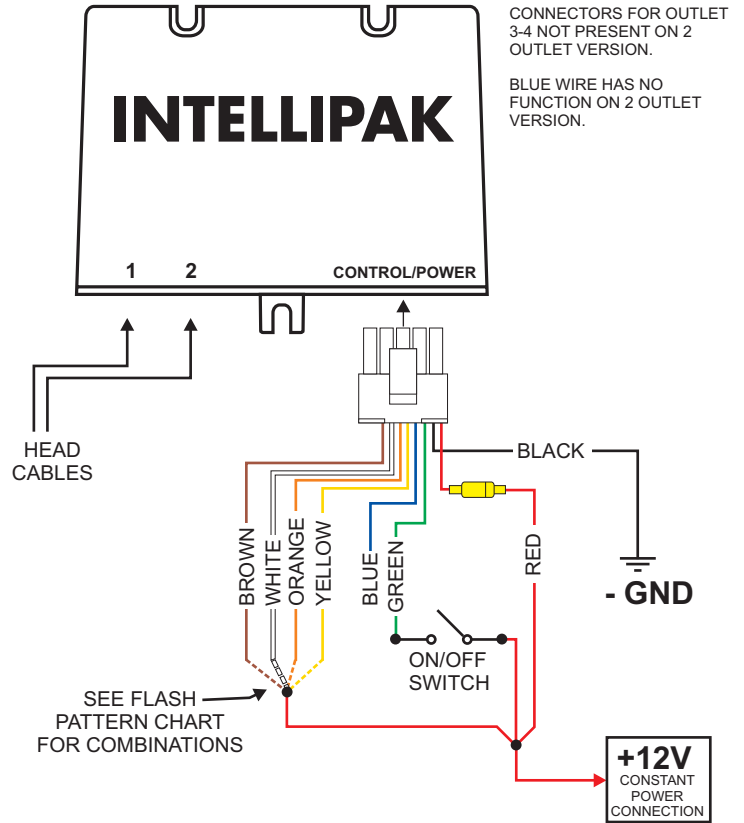

TROUBLESHOOTING

If the INTELLIPAK does not operate after it is installed check the following:

Control Wire: The GREEN wire must be connected to +12V for the unit to operate.

Check Fuse: The INTELLIPAK will blow a fuse if the input voltage is reversed. If this happens, first locate the wiring fault, then replace the fuse with one of the same rating. The INTELLIPAK is reverse polarity protected and will not be damaged.

Power Connections: Check for proper voltage (12V) across RED and BLACK wires on CONTROL/POWER connector. (Pins 1 and 6)

FLASH PATTERN TABLE

#:	BROWN	WHITE	ORANGE	YELLOW	FLASH PATTERN:	DESCRIPTION:
1					QUAD	4 Flashes alternating. 160 Quad Flashes Per Minute.
2				+12V	SPEED DOUBLE	2 Flashes alternating. 500 Double Flashes Per Minute.
3			+12V		MEGA! FLASH	1 Flash alternating. 750 Flashes Per Minute.
4			+12V	+12V	QUINTUPLE	5 Flashes alternating. 150 Quintuple Flashes Per Minute.
5		+12V			SPEED TRIPLE	3 Flashes alternating. 500 Triple Flashes Per Minute.
6		+12V		+12V	EXTREME	1 Flash alternating. 1200 Flashes Per Minute.
7		+12V	+12V		HYPER BLAST	1 Flash alternating. 600 Flashes Per Minute.
8		+12V	+12V	+12V	OCTAFLASH	8 Flashes alternating. 150 OctaFlashes Per Minute.
9	+12V				SCREAMING SINGLE	1 Flash alternating. 1000 Flashes Per Minute.
10	+12V			+12V	DECIBLAST	10 Flashes alternating. 171 DeciFlashes Per Minute.
11	+12V		+12V		SPEED TRIPLE	3 Flashes alternating. 500 Triple Flashes Per Minute.
12	+12V		+12V	+12V	QUAD-MEGA	Quad Flash and Mega Flash cycle.
13	+12V	+12V			RPM LEVEL 4	Random selection from Patterns 1-11. Level 4.
14	+12V	+12V		+12V	RPM LEVEL 4	Random selection from Patterns 1-11. Level 4.
15	+12V	+12V	+12V		RPM LEVEL 2	Random selection from Patterns 1-11. Level 2.
16	+12V	+12V	+12V	+12V	RPM LEVEL 2	Random selection from Patterns 1-11. Level 2.