

LEDWIC35

GROMMET MOUNT 3" X 5" LED HEAD



TECHNICAL SPECIFICATIONS

INPUT VOLTAGE	12.8 Vdc
INPUT CURRENT	0.4 Amps Typical
	0.8 Amps Max
	(varies with flash pattern)
LED ELEMENTS	56
FLASH PATTERNS.....	15

DIMENSIONS

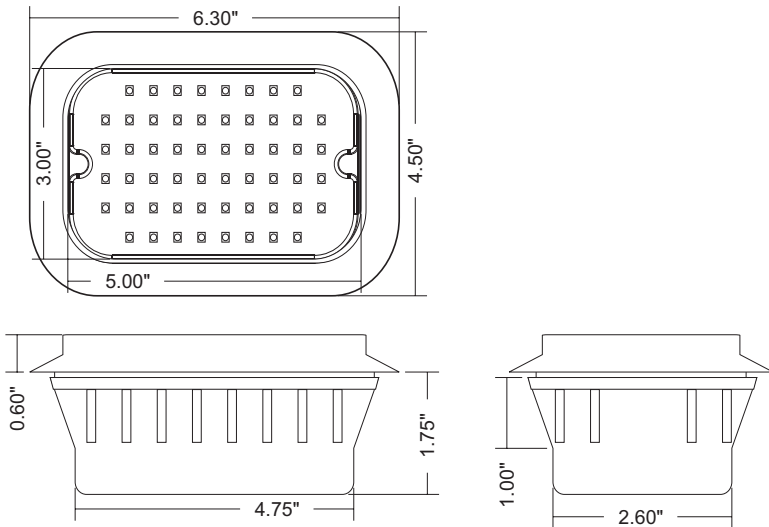

INSTALLING THE LEDWIC35

(1) Use the HOLE TEMPLATE to mark and cut the mounting hole for the LEDWIC35.

(2) Make Electrical Connections: *Wiring diagrams on back*

THE WIRE CONNECTIONS MUST BE SEALED IF USED IN A WET LOCATION. WATER MAY TRAVEL UP AN UN-SEALED WIRE AND CAUSE CORROSION PROBLEMS.

USE AT LEAST 18AWG WIRE FOR POWER CONNECTIONS

RED Wire: Connect to +12V through an ON/OFF switch.

The use of a fuse located close to the voltage source is recommended.

BLACK Wire: Connect to - GROUND *vehicle chassis*.

BLUE Wire: Flash Pattern Selection.

Turn the power switch on. Touch the BLUE wire to +12V (RED wire) to advance to the next pattern. When you have found the flash pattern you wish to use, either leave the BLUE wire unconnected (SEAL THE END) or connect to GROUND (BLACK wire).

See flash pattern list on next page.

(3) Press the LEDWIC35 into the mounting hole.
(Do not press directly on the lens)

HOLE TEMPLATE

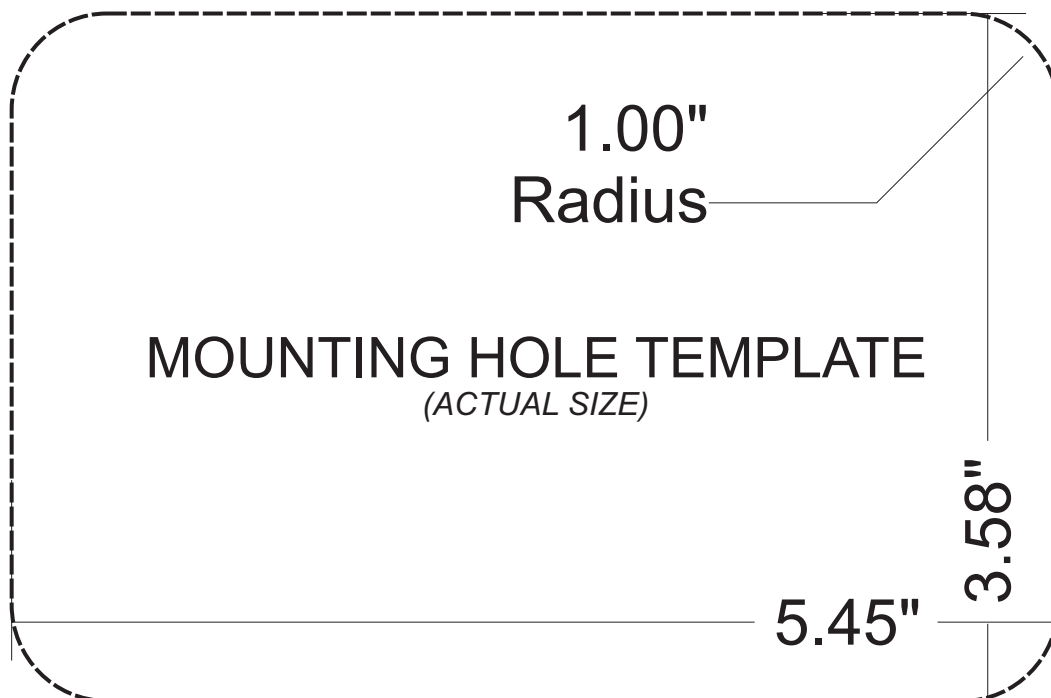

WIRING DIAGRAM 1

BASIC WIRING WITH SIMPLE ON/OFF SWITCH

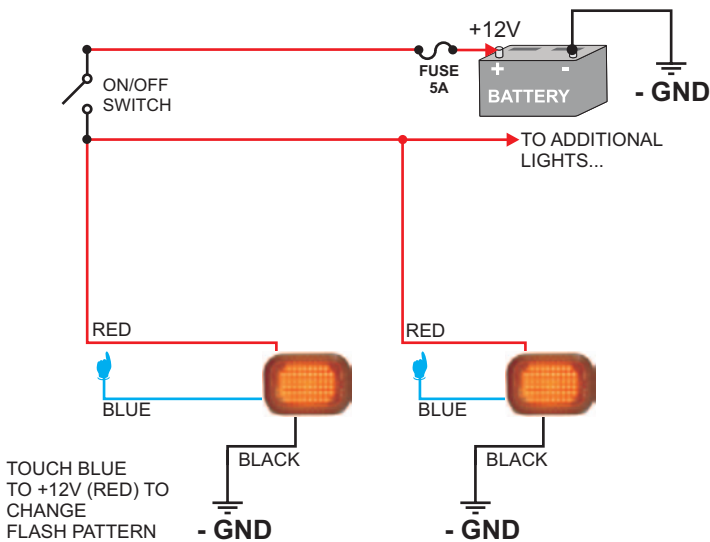

WIRING DIAGRAM 2

ON/OFF AND FLASH PATTERN SELECTION

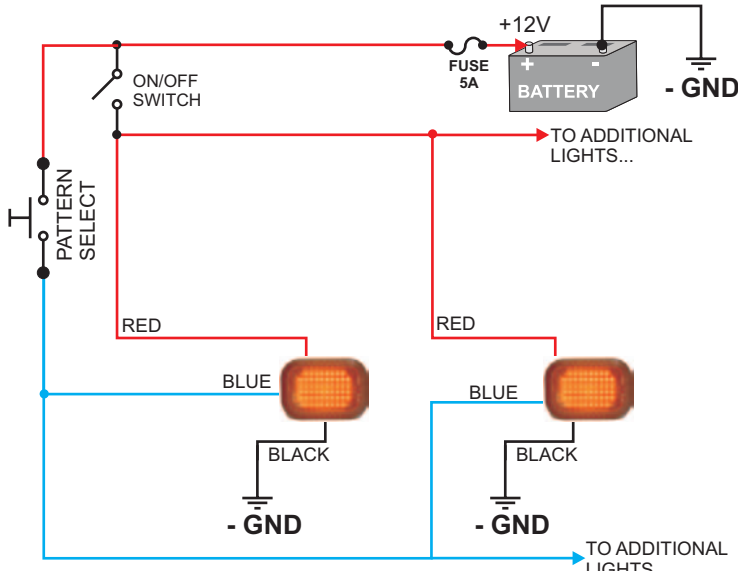

PATTERN SELECT SWITCH IS A MOMENTARY, NORMALLY OFF, PUSHBUTTON SWITCH.

PRESSING PATTERN SELECT WILL INCREMENT THE FLASH PATTERN.

PRESS AND HOLD PATTERN SELECT WHILE TURNING THE POWER SWITCH ON TO RESET FLASH PATTERN TO #1.

FLASH PATTERN LIST

#	Flash Pattern	Description
1	Steady ON	All LEDs on. FOR USE WITH EXTERNAL FLASHER ONLY.
2	RANDOM	Randomly selects from patterns 3 through 13 and runs each pattern 10 times.
3	Double Flash - SPLIT	2 Flash Bursts Alternating between split LED array. 115 Double FPM.
4	Quad Flash - SPLIT	4 Flash Bursts Alternating between split LED array. 140 Quad FPM.
5	Mega Flash - SPLIT	1 Flash Burst Alternating between split LED array. 500 FPM.
6	Phased Mega - SPLIT	1 Flash Burst Alternating between split LED array. Varies from 360 to 1200 FPM.
7	Deciblast - SPLIT	10 Flash Bursts Alternating between split LED array. 170 Deci FPM.
8	Double Flash	2 Flash Bursts. All LEDs firing. 115 Double Flashes Per Minute.
9	Quad Flash	4 Flash Bursts. All LEDs firing. 140 Quad Flashes Per Minute.
10	Mega Flash	1 Flash Burst. All LEDs firing. 500 Flashes Per Minute.
11	Phased Mega	1 Flash Burst. All LEDs firing. Varies from 360 to 1200 Flashes Per Minute.
12	Deciblast	10 Flash Bursts. All LEDs firing. 170 Deci Flashes Per Minute.
13	Flasher - SPLIT	Wig-Wag Flasher pattern split across LED array. 3 Flashes per second rate.
14	Flasher Sequence 1 - SPLIT	Wig-Wag and Steady Flasher sequence 1. 3 Flashes per second rate.
15	Flasher Sequence 2 - SPLIT	Wig-Wag and Steady Flasher sequence 2. 3 Flashes per second rate.

CONNECTION TO FLASHER

The LEDWIC35 can be driven by any lamp flasher or LED flasher that is made to drive +12 Volt lamps or LED heads.

SET THE LEDWIC35 TO PATTERN 1
STEADY ON
WHEN USING WITH FLASHER

The easiest way to set the LEDWIC35 to steady on mode is to temporarily twist BLUE and RED together and apply power. Then, tie BLUE to the BLACK wire to ensure that the flash pattern will never change from steady on mode.

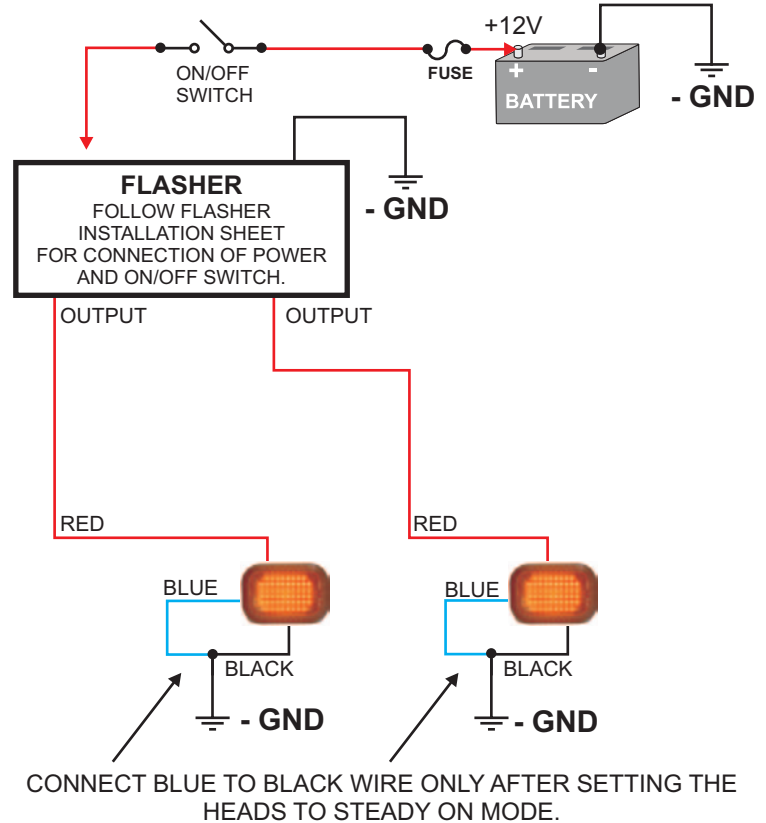

SEALING WIRE CONNECTIONS

ELECTRICAL TAPE WILL NOT SEAL A CONNECTION

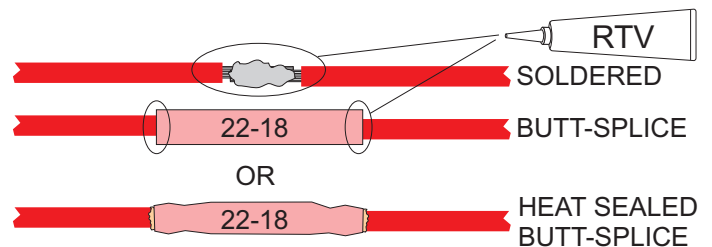

Patterns 3 through 7 and 13 through 15 split the LED array into two halves

The remaining patterns flash the entire LED array.

RANDOM mode picks from both split and full array flash patterns.

