

SLULTRA

ULTRA THIN SURFACE MOUNT LED HEAD

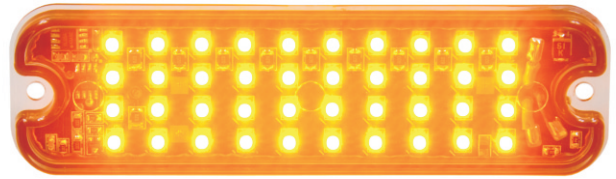

TECHNICAL SPECIFICATIONS

INPUT VOLTAGE	12.8 Vdc
INPUT CURRENT	0.2 Amps Typical
	0.5 Amps Max
	(varies with flash pattern)
LED ELEMENTS	40
FLASH PATTERNS.....	8

DIMENSIONS

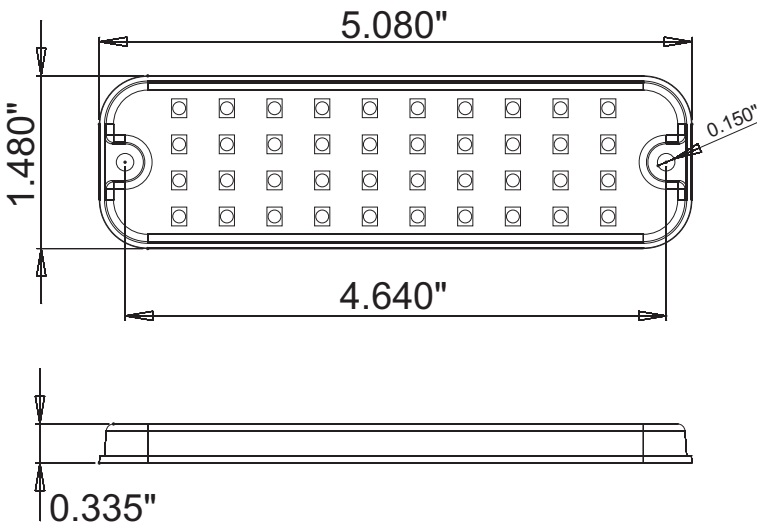

INSTALLING THE SLULTRA

- (1) Use the HOLE TEMPLATE to mark the hole locations for the two mounting screws and the wires. Drill 7/64" pilot holes for the mounting screws and a 1/2" hole for the wires.
- (2) Make Electrical Connections: *Wiring diagrams on back*

THE WIRE CONNECTIONS MUST BE SEALED IF USED IN A WET LOCATION. WATER MAY TRAVEL UP AN UN-SEALED WIRE AND CAUSE CORROSION PROBLEMS.

- USE AT LEAST 18AWG WIRE FOR POWER CONNECTIONS**
- RED** Wire: Connect to +12V through an ON/OFF switch. The use of a fuse located close to the voltage source is recommended.
- BLACK** Wire: Connect to - GROUND *vehicle chassis*.
- BLUE** Wire: Flash Pattern Selection.
- Turn the power switch on. Touch the BLUE wire to +12V (RED wire) to advance to the next pattern. When you have found the flash pattern you wish to use, either leave the BLUE wire unconnected (SEAL THE END) or connect to GROUND (BLACK wire).
- See flash pattern list on next page.*
- (3) Mount the SLULTRA with the two #6x1/2" stainless steel screws (supplied). *NOTE: The SLULTRA should not be mounted to an extremely curved surface.*

HOLE TEMPLATE

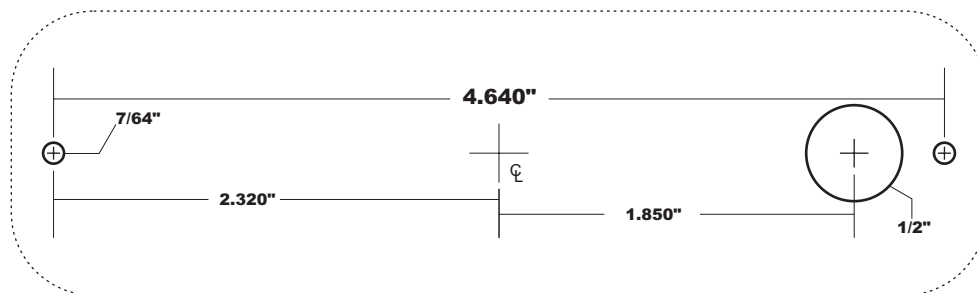

ACTUAL SIZE

WIRING DIAGRAM 1

BASIC WIRING WITH SIMPLE ON/OFF SWITCH

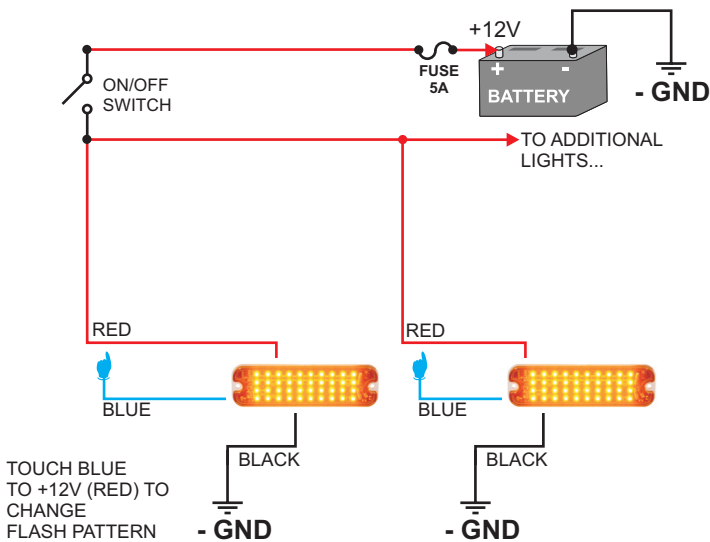

WIRING DIAGRAM 2

ON/OFF AND FLASH PATTERN SELECTION

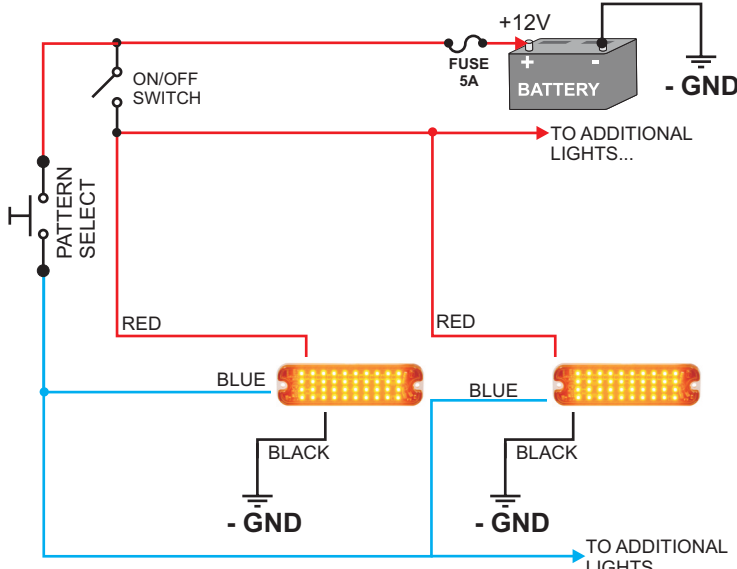

PATTERN SELECT SWITCH IS A MOMENTARY, NORMALLY OFF, PUSHBUTTON SWITCH.

PRESSING PATTERN SELECT WILL INCREMENT THE FLASH PATTERN.

PRESS AND HOLD PATTERN SELECT WHILE TURNING THE POWER SWITCH ON TO RESET FLASH PATTERN TO #1.

CONNECTION TO FLASHER

The SLULTRA can be driven by any lamp flasher or LED flasher that is made to drive +12 Volt lamps or LED heads.

SET THE SLULTRA TO PATTERN 1
STEADY ON
WHEN USING WITH FLASHER

The easiest way to set the SLULTRA to steady on mode is to temporarily twist BLUE and RED together and apply power. Then, tie BLUE to the BLACK wire to ensure that the flash pattern will never change from steady on mode.

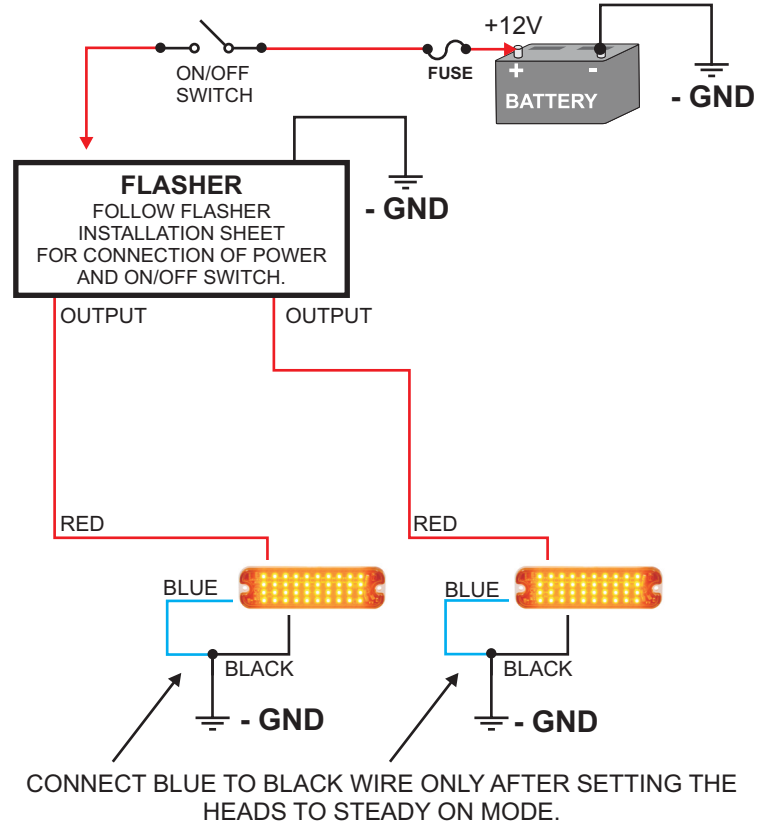

SEALING WIRE CONNECTIONS

ELECTRICAL TAPE WILL NOT SEAL A CONNECTION

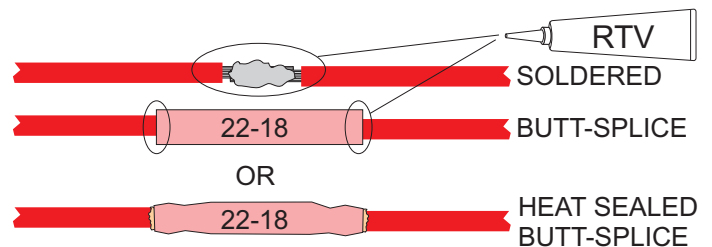

FLASH PATTERN LIST

#	Flash Pattern	Description
1	Steady ON	All LEDs on. FOR USE WITH EXTERNAL FLASHER ONLY.
2	RANDOM	Randomly selects from patterns 3 through 8 and runs each pattern 10 times.
3	Double Flash	2 Flash Bursts. All LEDs firing. 115 Double Flashes Per Minute.
4	Quad Flash	4 Flash Bursts. All LEDs firing. 140 Quad Flashes Per Minute.
5	Mega Flash	1 Flash Burst. All LEDs firing. 500 Flashes Per Minute.
6	Phased Mega	1 Flash Burst. All LEDs firing. Varies from 360 to 1200 Flashes Per Minute.
7	Deciblast	10 Flash Bursts. All LEDs firing. 170 Deci Flashes Per Minute.
8	Flasher	Wig-Wag Flasher pattern. 3 Flashes per second flash rate.