

DOUBLEX-PAK 1208



IMPORTANT! This product is **NOT** waterproof. It must be mounted to a metal surface in a clean dry area.



TECHNICAL SPECIFICATIONS

INPUT VOLTAGE	10 to 30 Vdc
INPUT CURRENT	11A at 12.8V, 5.2A at 25.6V
INPUT POWER	150 Watts
OUTPUT POWER	120 Watts
OUTPUT ENERGY	103 Joules
FLASH RATES	
Double Flash:	170 flashes per minute.
Quad Flash:	140 flashes per minute.
Quintuple Flash:	140 flashes per minute.
Mega Flash:	140 flashes per minute.

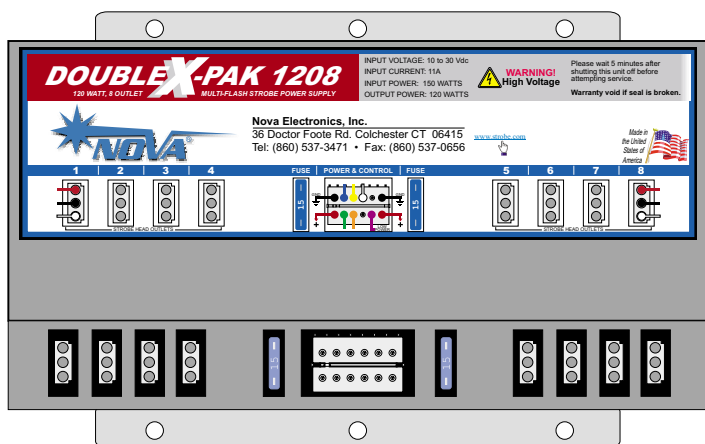

INSTALLING THE DOUBLEX-PAK 1208

1. Mounting Considerations

Mount the power supply in a clean, dry location. Mounting the unit to a flat metal surface will aid in heat dissipation. Use the power supply as a template to mark the hole locations. The mounting holes will accept up to a 1/4" bolt. *Note: The power supply baseplate must be connected to chassis ground (GND) to reduce radio interference.*

2. Strobe Head installation

Plug the strobe light heads into the outlets. The *Flash Pattern Table* on the next page describes which heads flash at the same time, etc.

3. Electrical Hookup

If you have purchased a pre wired switch harness, follow the included instructions. If you are wiring the system yourself follow the instructions below and the diagrams on the next page.

POWER WIRING:

- Connect the RED wires to battery positive (+) or a fuse panel circuit rated for at least 20 AMPS.
- Connect the BLACK wires to battery negative (-) or directly to vehicle chassis.

Note: Use the correct size wire for power connections.

The length of the wires determines the size needed.

1 to 10 ft. use 18AWG wire.

10 to 20 ft. use 16AWG wire.

20 to 35 ft. use 14AWG wire.

35 to 50 ft. use 12AWG wire.

- The VIOLET wire controls HIGH / LOW power. Low power limits the flash intensity for nighttime use. Connect VIOLET to +12/24V for LOW power, leave VIOLET disconnected for HIGH power.

CONTROL WIRING

- YELLOW, GREEN, BLUE, WHITE, and ORANGE wires select the flash pattern and also control which strobe head outlets are activated. A wire is 'selected' when connected to +12/24V. When all control wires are unconnected the power supply is in a low current SHUTDOWN MODE (Current is typically 25ma).

See the *Flash Pattern Table* on the next page for a complete list of functions.

Note: VIOLET, YELLOW, GREEN and BLUE are all Low Current circuits and can be wired with a minimum of 22AWG wire.

CONNECTOR DIAGRAMS

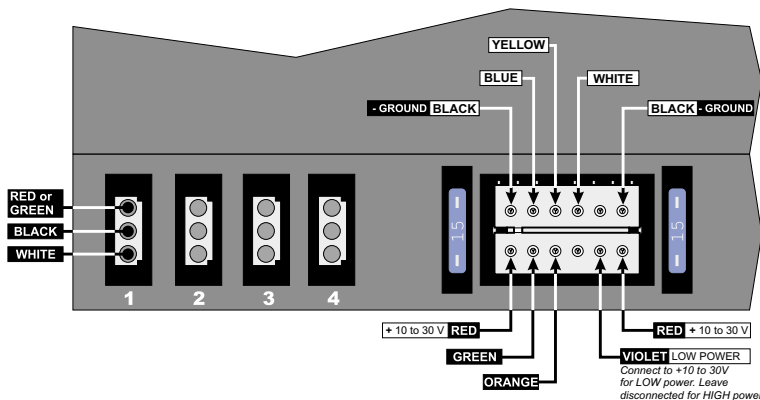

STROBE HEAD EXTENSION CABLE

