

HPS4-80



IMPORTANT! This product is **NOT** waterproof. It must be mounted to a metal surface in a clean dry area.



TECHNICAL SPECIFICATIONS

INPUT VOLTAGE	10 to 30 Vdc
INPUT CURRENT	7.75A at 12.8V, 4A at 25.6V
INPUT CURRENT (Shutdown Mode)....	Less than 25ma
INPUT POWER	100 Watts
OUTPUT POWER	80 Watts
FLASH ENERGY (In Joules)	
SINGLE FLASH.....	28.2 Joules Primary Flash
DOUBLE FLASH.....	28.5 Joules Primary Flash, 12.5 Joules Secondary Flash (41 Joules Total!)
FLASH RATES	
SINGLE FLASH.....	175 Flashes per minute.

CONNECTION DIAGRAMS

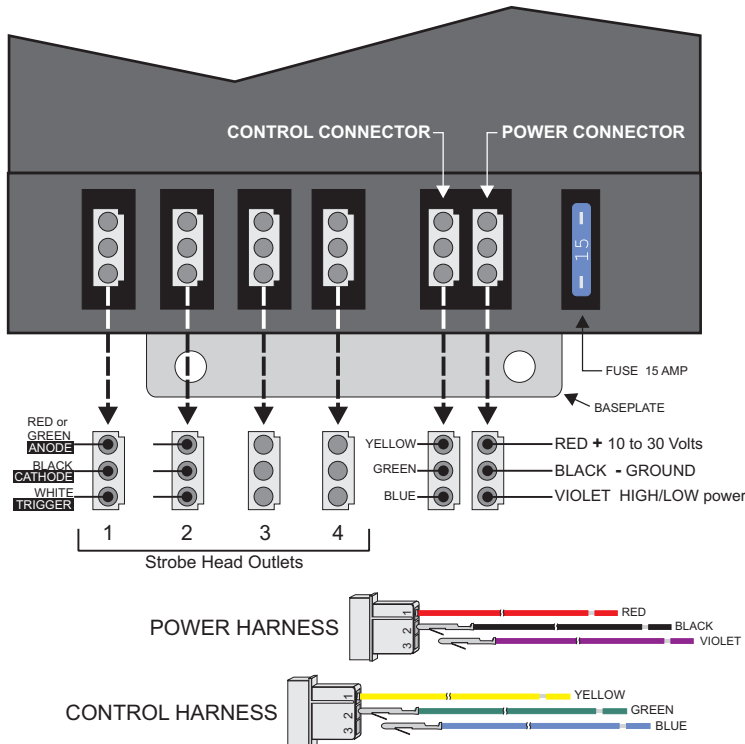

INSTALLATION PROCEDURE

1. Mounting Considerations

Mount the power supply in a clean, dry location. Mounting the unit to a flat metal surface will aid in heat dissipation. Use the power supply as a template to mark the hole locations. The mounting holes will accept up to a 1/4" bolt. *Note: The power supply baseplate must be connected to chassis ground (GND) to*

INSTALLING THE HPS4-80

2. Strobe Head installation

Plug the remote strobe heads into the outlet connectors. The strobe head 'mapping' is as follows:

- Heads connected to outlets 1 and 3 flash at the same time.
- Heads connected to outlets 2 and 4 flash at the same time.
- Heads connected to 1 and 3 alternate with heads 2 and 4.

Attention: This power supply is capable of overloading standard strobe heads. It is recommended that you use only HPS certified strobe heads on this power supply.



USE ONLY
HPS CERTIFIED
STROBE HEADS

HIGH POWER SYSTEM
HEADS ARE RATED FOR
55 WATTS, 55 JOULES

3. Electrical Hookup

If you have purchased a pre-wired switch harness, follow the included instructions. If you are wiring the system yourself follow the instructions below and the diagrams on the next page.

Wiring the POWER HARNESS:

Connect the **RED** wire to battery positive (+) or a fuse panel circuit rated for at least 15 AMPS. Connect the **BLACK** wire to battery negative (-) or directly to vehicle chassis. Use the proper size wire for best performance.

Length to run 2 conductors: Recommended wire size:

1 to 5 Feet	Use 18AWG Wire.
5 to 10 Feet	Use 16AWG Wire.
10 to 20 Feet	Use 14AWG Wire.
20 to 35 Feet	Use 12AWG Wire.
35 to 50 Feet +	Use 10AWG Wire.

The **VIOLET** wire controls HIGH/LOW power. Low power limits the flash intensity for nighttime use. Connect **VIOLET** to +12/24V for LOW power, leave **VIOLET** disconnected for HIGH power.

Wiring the CONTROL HARNESS:

Connect the **GREEN** wire to +12/24V to activate outlets 1 and 4. Connect the **BLUE** wire to +12/24V to activate outlets 2 and 3. When both the **GREEN** and **BLUE** wires are unconnected the power supply is in a low current consumption SHUTDOWN mode. Connect the **YELLOW** wire to +12/24V to select the SINGLE FLASH flash pattern. Leave **YELLOW** disconnected to select the DOUBLE FLASH flash pattern. See the PATTERN TABLE on the next page for a complete list of functions.

Note: VIOLET, YELLOW, GREEN and BLUE are all Low Current

WIRING/CONNECTION DIAGRAMS

DIAGRAM (1): ON/OFF and Low Power using two toggle

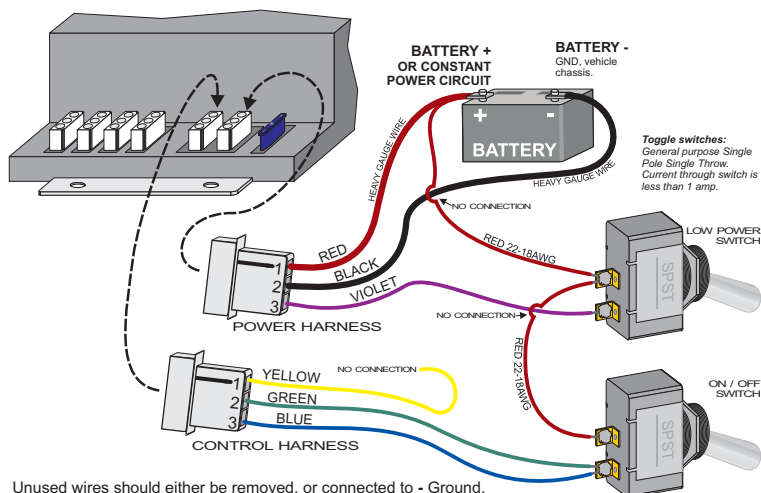

Unused wires should either be removed, or connected to - Ground.

DIAGRAM (2): ON/OFF and Low Power using one DPDT

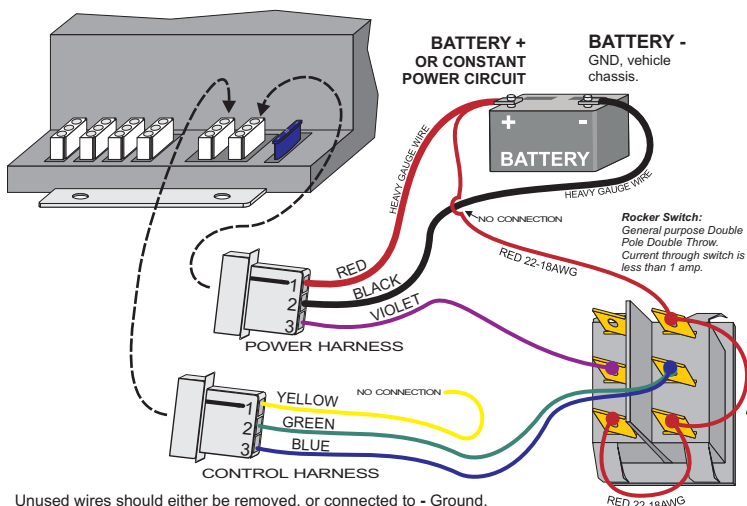

Unused wires should either be removed, or connected to - Ground.

DIAGRAM (3): Selective switching of strobe head pairs. Low

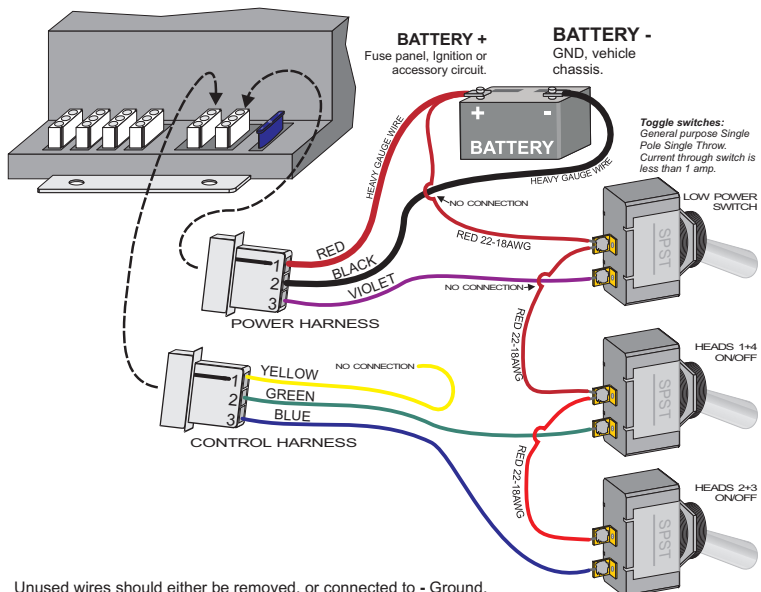

Unused wires should either be removed, or connected to - Ground.

PATTERN TABLE

Selecting a flash pattern: In the table below, find the desired flash pattern. Connect the wires marked **POWER** to +12/24V (Typically through a switch). Any unused wires should be removed or connected to Ground (-).

Example: Diagram 1 uses pattern #4 (Double Flash, All Heads). To change this to pattern #8 (Single flash, All Heads) connect the **YELLOW**, **BLUE**, and **GREEN** wires

PATTERN	YELLOW	GREEN	BLUE	FUNCTION
1				SHUTDOWN
2			POWER	Double Flash 120FPM, Heads 2+3
3		POWER		Double Flash 120FPM, Heads 1+4
4		POWER	POWER	Double Flash 120FPM, All Heads
5	POWER			SHUTDOWN
6	POWER		POWER	Single Flash 175FPM, Heads 2+3
7	POWER	POWER		Single Flash 175FPM, Heads 1+4
8	POWER	POWER	POWER	Single Flash 175FPM, All Heads

TROUBLESHOOTING

Blown Fuse: The HPS4-80 will blow a fuse if the input voltage is reversed. If this happens, first locate the wiring fault, then replace the fuse with one of the same rating.

Erratic behavior (and/or) shutdown: The HPS4-80 will shut down if there is a short circuit condition on any one of the strobe heads. If the electrical conductors connecting the power supply to the strobe heads are exposed to water a short circuit will result. The first sign is intermittent operation, followed by complete shutdown of the strobe system. To find the short circuit, unplug all strobe head cables from the HPS4-80. Test **one** cable/head at a time

ACCESSORIES

The following accessories are available to make the installation of the HPS4-80 power supply even easier:

ON/OFF - LOW POWER SWITCH PANEL

A Fully assembled switch panel which provides simple On/Off and Low power control. Provides the same functions as shown in Diagram (1)

SELECTIVE SWITCHING PANEL

A Fully assembled switch panel which allows selective switching of strobe head pairs and also includes Low power control. Provides the same functions as shown in Diagram (3)