

ULTRA-PAK 18510

 **IMPORTANT!** This product is **NOT** waterproof. It must be mounted to a metal surface in a clean dry area. 

TECHNICAL SPECIFICATIONS

INPUT VOLTAGE	10 to 16 Vdc
INPUT CURRENT	18A at 12.8V
INPUT POWER	230 Watts
OUTPUT POWER	185 Watts
FLASH RATES	
Double Flash:	170 flashes per minute.
Quad Flash:	140 flashes per minute.
Quintuple Flash:	140 flashes per minute.
Mega Flash:	140 flashes per minute.

INSTALLING THE ULTRA-PAK 18510

- Mounting Considerations**
Mount the power supply in a clean, dry location. **It is highly recommended that the unit be mounted to a flat metal surface to aid in heat dissipation.** Use the power supply as a template to mark the hole locations. The mounting holes will accept up to a 1/4" bolt. *Note: The power supply baseplate must be connected to chassis ground (GND) to reduce radio interference.*
- Strobe Head installation**
Do not connect less than 4 strobe heads to the left side of the power supply. This may overheat the strobe heads. The *Flash Pattern Table* on the next page describes which heads flash at the same time, etc.
- Electrical Hookup**
If you have purchased a pre wired switch harness, follow the included instructions. If you are wiring the system yourself follow the instructions below and the diagrams on the next page.

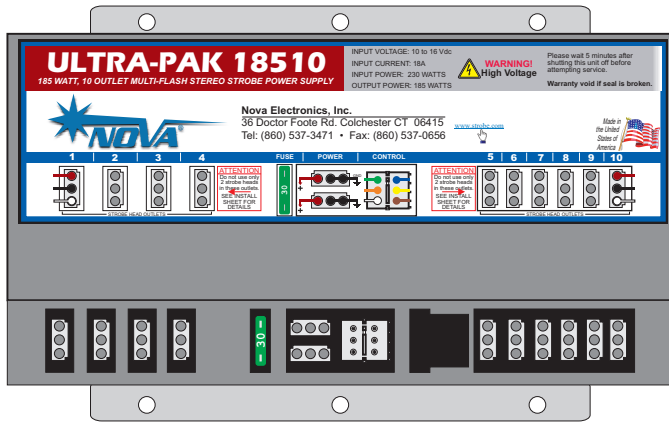

CONNECTOR DIAGRAMS

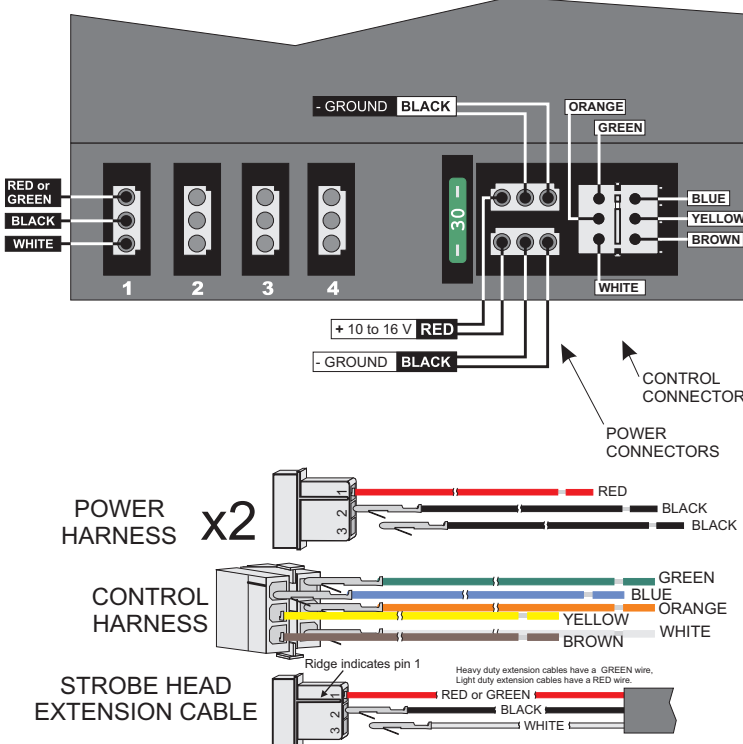

POWER WIRING:

- Connect the RED wires to battery positive (+) or a fuse panel circuit rated for at least 25 AMPS.
- Connect all four of the BLACK wires directly to vehicle chassis GND.

Note: Use the correct size wire for power connections.

The length of the wires determines the size needed.

1 to 10 ft. use 16AWG wire.

10 to 20 ft. use 14AWG wire.

20 to 35 ft. use 12AWG wire.

35 to 50 ft. use 10AWG wire.

The use of at least 14AWG wire is highly recommended.

CONTROL WIRING

- YELLOW, GREEN, and BLUE wires activate strobe head outlets. Each wire controls 4 outlets.
- WHITE, ORANGE, and BROWN wires select the flash pattern. See the *Flash Pattern Table* on the next page for a complete list of functions.

Control wires are 'selected' by connecting to +12V. When all control wires are unconnected, or 'SHUTDOWN' pattern is selected the power supply is set to a low current *Standby Mode*. Input current is typically less than 25ma (.025A).

Note: YELLOW, GREEN, BLUE, WHITE, ORANGE, BROWN are all Low Current circuits and can be wired with a minimum of 22AWG wire.

SELECTING OUTLETS/FLASH PATTERNS

Activating Strobe Head Outlets: Connecting wire to +12V activates the outlets shown.

BLUE wire: Activates Outlets 1&2 and 5&6

GREEN wire: Activates Outlets 3& 4 and 7&8

YELLOW wire: Activates outlets 9&10

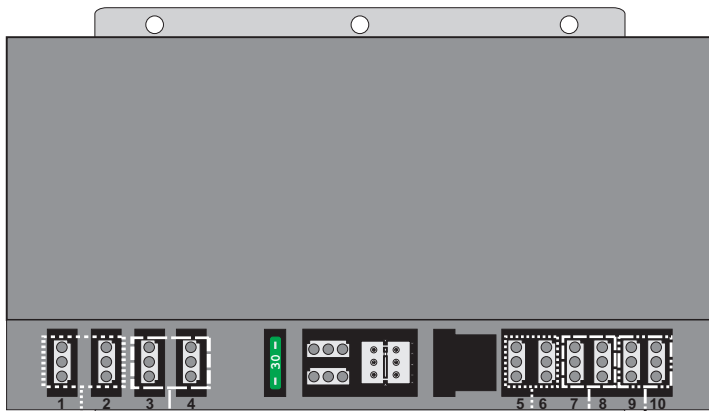

BLUE
GREEN
YELLOW

! WARNING !

Activating heads 1&2, 5&6, 9&10 by connecting YELLOW and BLUE to +12V will deliver 92 Watts to heads **1&2!**

Activating heads 3&4, 5&6, 9&10 by connecting YELLOW and GREEN to +12V will deliver 92 Watts to heads **3&4!**

In the two situations described above, each strobe head will receive 46 Watts. This may exceed the ratings of the strobe head. Heads 5 - 10 automatically reduce the output power when only 2 strobe heads are activated.

(The above warning applies only to the 10 head power supply. The 8 and 12 head supplies automatically adjust when only 2 heads are activated per side.)

Selecting a flash pattern: In the table below, find the desired flash pattern. Connect the wires marked **POWER** to +12v or the 'load' side of the ON/OFF switch. Remove the remaining wires, or connect them to - Ground.

Flash Pattern Table

#	BROWN	WHITE	ORANGE	FLASH PATTERN
1				SHUTDOWN
2			POWER	Quad Flash
3		POWER		Mega Flash
4		POWER	POWER	Double Flash
5	POWER			Mega Flash 1-4, Quad Flash 5-10
6	POWER		POWER	Double Flash 1-4, Mega Flash 5-10
7	POWER	POWER		Quintuple Flash 1-4, Mega Flash 5-10
8	POWER	POWER	POWER	Quad Flash 1-4, Double Flash 5-10

WIRING/CONNECTION DIAGRAMS

DIAGRAM (1): ON/OFF Switch, Fixed flash pattern. Choose flash pattern from table.

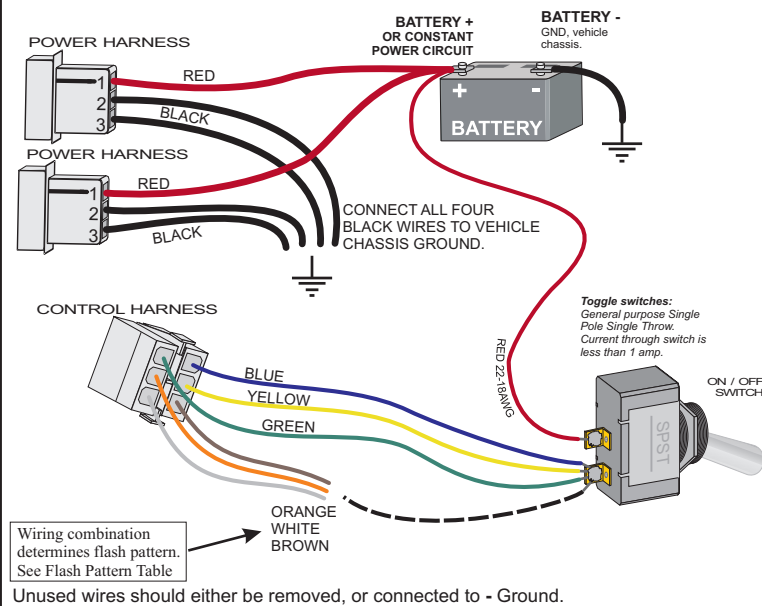
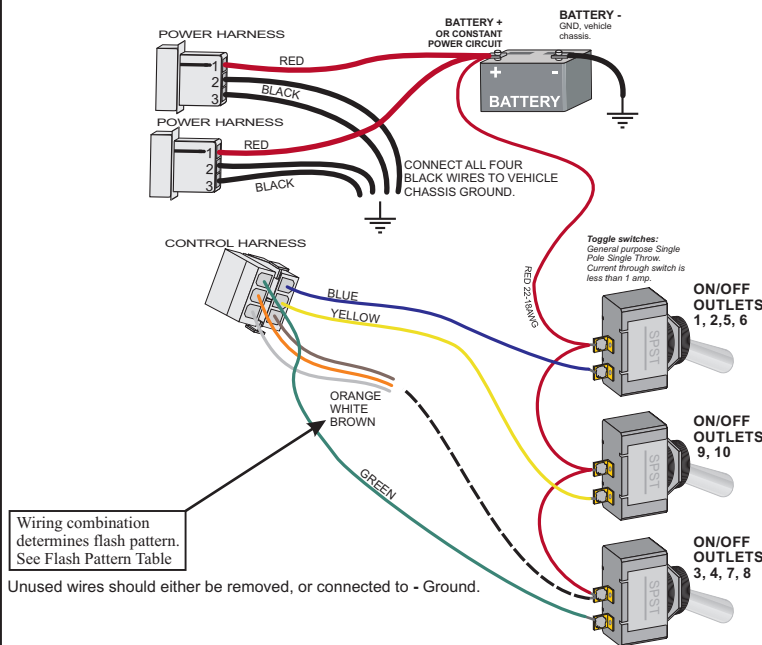

DIAGRAM (2): Selective switching of Strobe Heads using toggle switches. Fixed flash pattern. Choose flash pattern from table.



TROUBLESHOOTING

Blown Fuse: The ULTRA-PAK 18510 will blow a fuse if the input voltage is reversed. If this happens, first locate the wiring fault, then replace the fuse with one of the same rating.

Erratic behavior (and/or) shutdown: The ULTRA-PAK 18510 will shut down if there is a short circuit condition on any one of the strobe heads. If the electrical conductors connecting the power supply to the strobe heads are exposed to water a short circuit will result. The first sign is intermittent operation, followed by complete shutdown of the strobe system. To find the short circuit, unplug all strobe head cables from the ULTRA-PAK 18510. Test **one** cable/head at a time until the problem is found.