

# INSTALLATION SHEET



## 4.5" ROUND STROBE HEAD

### PARTS INCLUDED

- (1) 4.5" Round Strobe Head
- (1) Mounting Grommet
- (1) Installation Sheet

### INSTALLATION

(1) This strobe head requires a 4 1/2" hole for mounting and needs 2 1/2" of rear clearance. You can use the template on the back of this sheet to mark and cut the hole for the 4.5" ROUND STROBE HEAD.

Note: Some truck bodies come standard with this size hole.

(2) Install the black grommet into the hole.

(3) Run the extension cable through the hole and connect to the 4.5" ROUND STROBE HEAD. Seal the connectors with Silicone RTV sealant. (See diagrams on back of sheet)

(4) Press the 4.5" ROUND STROBE HEAD into the grommet to complete the installation.

### ! WARNING !

The 4.5" ROUND STROBE HEAD connectors must be sealed to prevent water and salt from attacking the high voltage connections. When properly sealed, the 4.5" ROUND STROBE HEAD is 100% watertight.

(NOTE: 4.5" ROUND STROBE HEADS sold with watertight connectors do not need to be sealed.)

Use RTV silicone sealant only!

**SILICONE GREASE will not seal the connectors!**

(G.E. RTV102 silicone sealant is recommended)

### WARRANTY IS VOID!

Unit warranty is void if the connector has not been properly sealed.

**MAKE SURE THE CONNECTIONS ARE WATERTIGHT!**

# INSTALLATION SHEET



## 4.5" ROUND STROBE HEAD

### PARTS INCLUDED

- (1) 4.5" Round Strobe Head
- (1) Mounting Grommet
- (1) Installation Sheet

### INSTALLATION

(1) This strobe head requires a 4 1/2" hole for mounting and needs 2 1/2" of rear clearance. You can use the template on the back of this sheet to mark and cut the hole for the 4.5" ROUND STROBE HEAD.

Note: Some truck bodies come standard with this size hole.

(2) Install the black grommet into the hole.

(3) Run the extension cable through the hole and connect to the 4.5" ROUND STROBE HEAD. Seal the connectors with Silicone RTV sealant. (See diagrams on back of sheet)

(4) Press the 4.5" ROUND STROBE HEAD into the grommet to complete the installation.

### ! WARNING !

The 4.5" ROUND STROBE HEAD connectors must be sealed to prevent water and salt from attacking the high voltage connections. When properly sealed, the 4.5" ROUND STROBE HEAD is 100% watertight.

(NOTE: 4.5" ROUND STROBE HEADS sold with watertight connectors do not need to be sealed.)

Use RTV silicone sealant only!

**SILICONE GREASE will not seal the connectors!**

(G.E. RTV102 silicone sealant is recommended)

### WARRANTY IS VOID!

Unit warranty is void if the connector has not been properly sealed.

**MAKE SURE THE CONNECTIONS ARE WATERTIGHT!**

## INSTALLATION DIAGRAMS

### STEPS FOR SEALING CONNECTORS:

#### STEP #1: Make the connection.

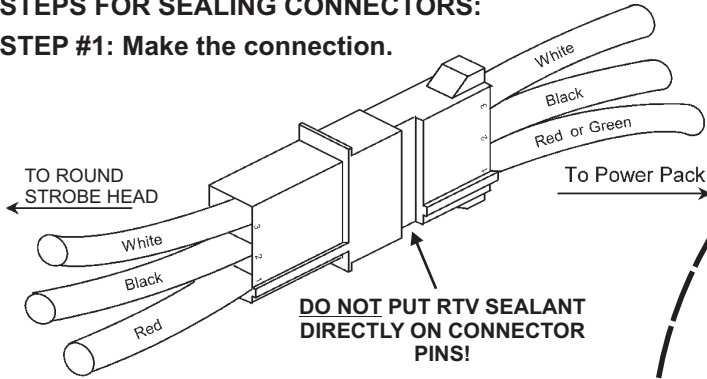

#### STEP #2: Apply RTV to all connector seams.

**NOTE: DO NOT SEAL WATERTIGHT CONNECTORS.**

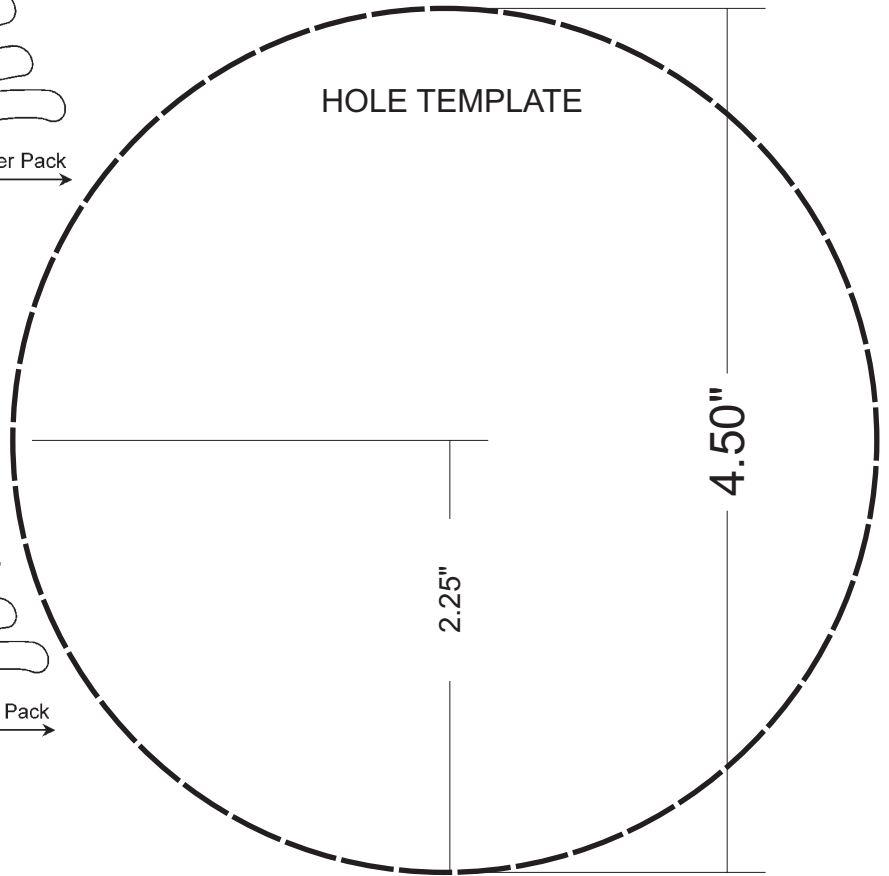
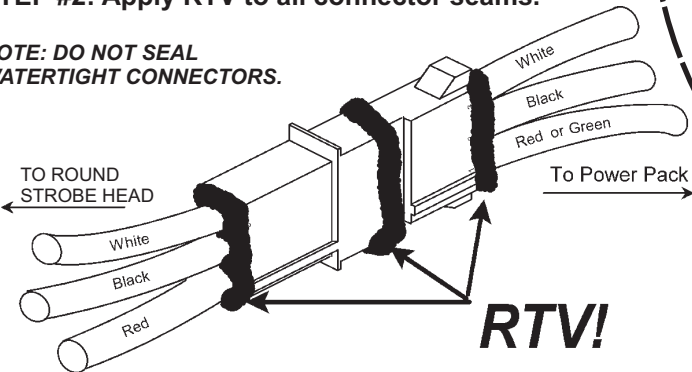

## INSTALLATION DIAGRAMS

### STEPS FOR SEALING CONNECTORS:

#### STEP #1: Make the connection.

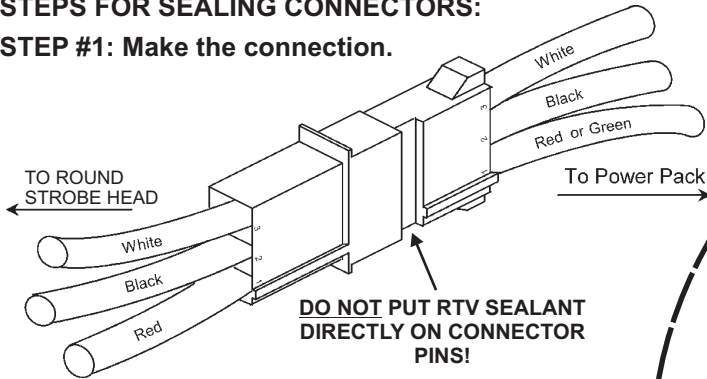

#### STEP #2: Apply RTV to all connector seams.

**NOTE: DO NOT SEAL WATERTIGHT CONNECTORS.**

