

## INSTALLATION SHEET



# OVAL STROBE HEAD

### PARTS INCLUDED

- (1) Oval Strobe Head with twist-lock tube installed.
- (1) Mounting Grommet
- (1) Installation Sheet

### INSTALLATION

- (1) Use the template on the back of this sheet to mark and cut the hole for the OVAL STROBE HEAD.
- (2) Install the black grommet into the hole.
- (3) Run the extension cable through the hole and connect to the OVAL STROBE HEAD. Seal the connectors with Silicone RTV sealant. (See diagrams on back of sheet)
- (4) Press the OVAL STROBE HEAD into the grommet to complete the installation.

The OVAL STROBE HEAD contains a replaceable twist-lock bulb. Contact your distributor for ordering information.

### ! WARNING !

The OVAL STROBE HEAD connectors must be sealed to prevent water and salt from attacking the high voltage connections. When properly sealed, the OVAL STROBE HEAD is 100% watertight.

(NOTE: OVAL STROBE HEADS sold with watertight connectors do not need to be sealed.)

Use RTV silicone sealant only!

**SILICONE GREASE will not seal the connectors!**

(G.E. RTV102 silicone sealant is recommended)

### WARRANTY IS VOID!

The OVAL STROBE HEAD warranty is void if there are signs of corrosion on the connector or if the connector is not properly sealed.

**MAKE SURE THE CONNECTIONS ARE WATERTIGHT!**

## INSTALLATION SHEET



# OVAL STROBE HEAD

### PARTS INCLUDED

- (1) Oval Strobe Head with twist-lock tube installed.
- (1) Mounting Grommet
- (1) Installation Sheet

### INSTALLATION

- (1) Use the template on the back of this sheet to mark and cut the hole for the OVAL STROBE HEAD.
- (2) Install the black grommet into the hole.
- (3) Run the extension cable through the hole and connect to the OVAL STROBE HEAD. Seal the connectors with Silicone RTV sealant. (See diagrams on back of sheet)
- (4) Press the OVAL STROBE HEAD into the grommet to complete the installation.

The OVAL STROBE HEAD contains a replaceable twist-lock bulb. Contact your distributor for ordering information.

### ! WARNING !

The OVAL STROBE HEAD connectors must be sealed to prevent water and salt from attacking the high voltage connections. When properly sealed, the OVAL STROBE HEAD is 100% watertight.

(NOTE: OVAL STROBE HEADS sold with watertight connectors do not need to be sealed.)

Use RTV silicone sealant only!

**SILICONE GREASE will not seal the connectors!**

(G.E. RTV102 silicone sealant is recommended)

### WARRANTY IS VOID!

The OVAL STROBE HEAD warranty is void if there are signs of corrosion on the connector or if the connector is not properly sealed.

**MAKE SURE THE CONNECTIONS ARE WATERTIGHT!**

## INSTALLATION DIAGRAMS

STEP #1: Make the connection.

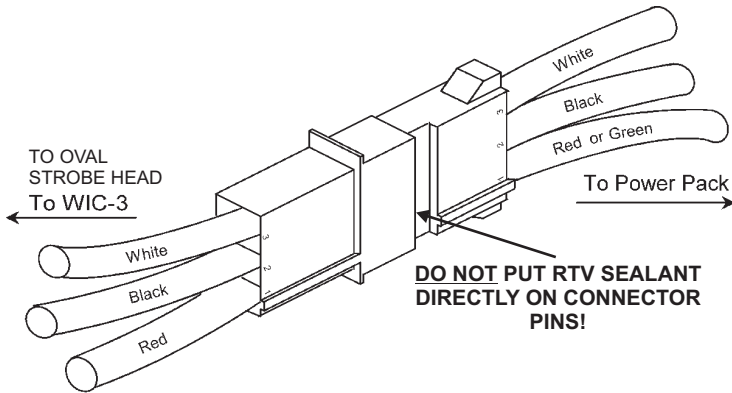

STEP #2: Apply RTV to all connector seams.

**NOTE: DO NOT SEAL WATERTIGHT CONNECTORS.**

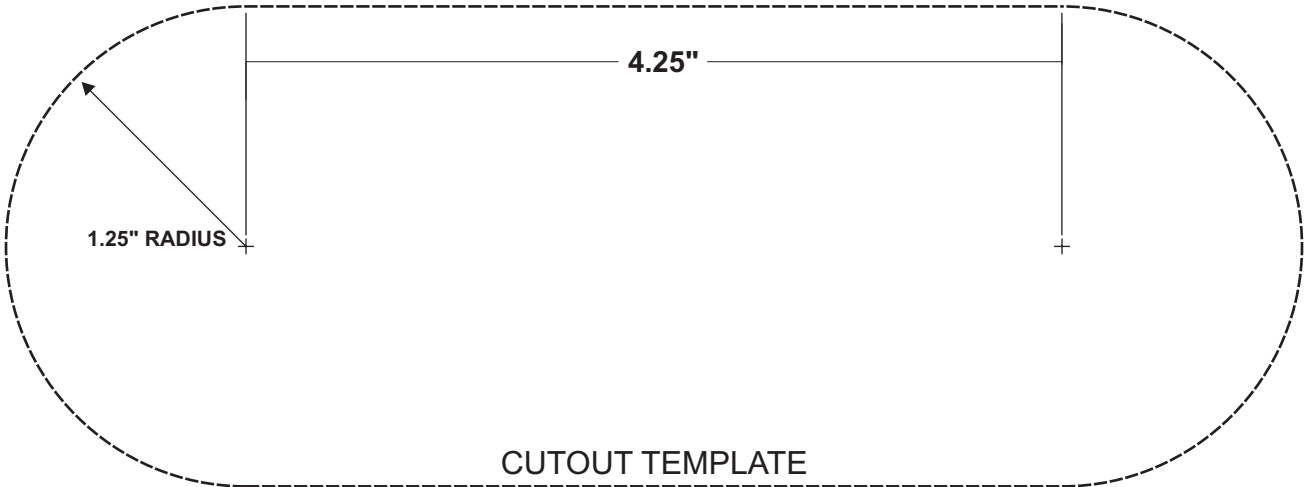
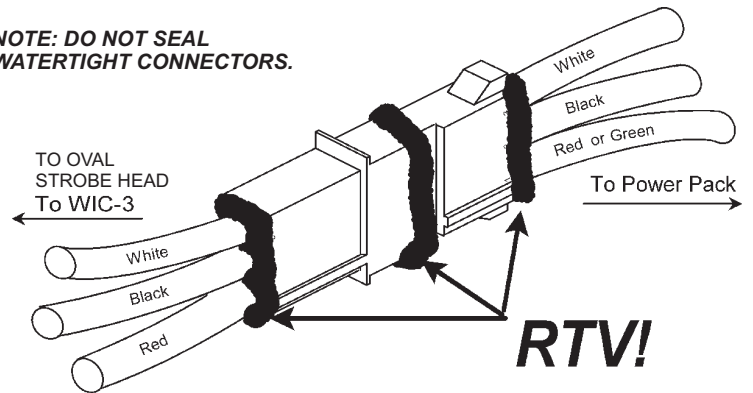

## INSTALLATION DIAGRAMS

STEP #1: Make the connection.

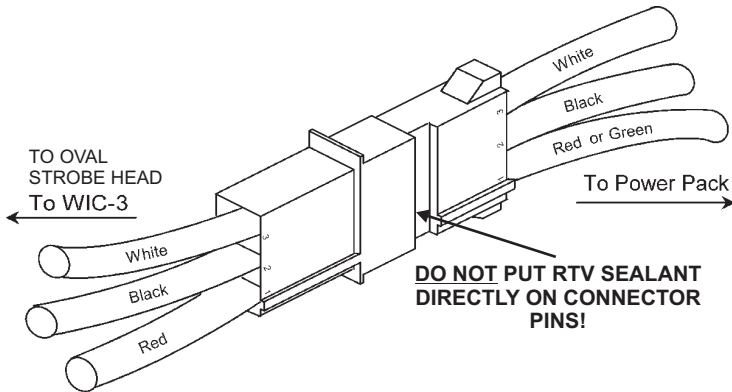

STEP #2: Apply RTV to all connector seams.

**NOTE: DO NOT SEAL WATERTIGHT CONNECTORS.**

