

X-PAK 604



IMPORTANT! This product is **NOT** waterproof. It must be mounted to a metal surface in a clean dry area.



TECHNICAL SPECIFICATIONS

INPUT VOLTAGE	10 to 30 Vdc
INPUT CURRENT	5.5A at 12.8V, 2.75A at 25.6V
INPUT POWER	70.4 Watts
OUTPUT POWER	60 Watts
OUTPUT ENERGY	51.5 Joules
FLASH RATES	
Double Flash:	170 flashes per minute.
Quad Flash:	140 flashes per minute.
Quintuple Flash:	140 flashes per minute.
Mega Flash:	140 flashes per minute.

CONNECTION DIAGRAMS

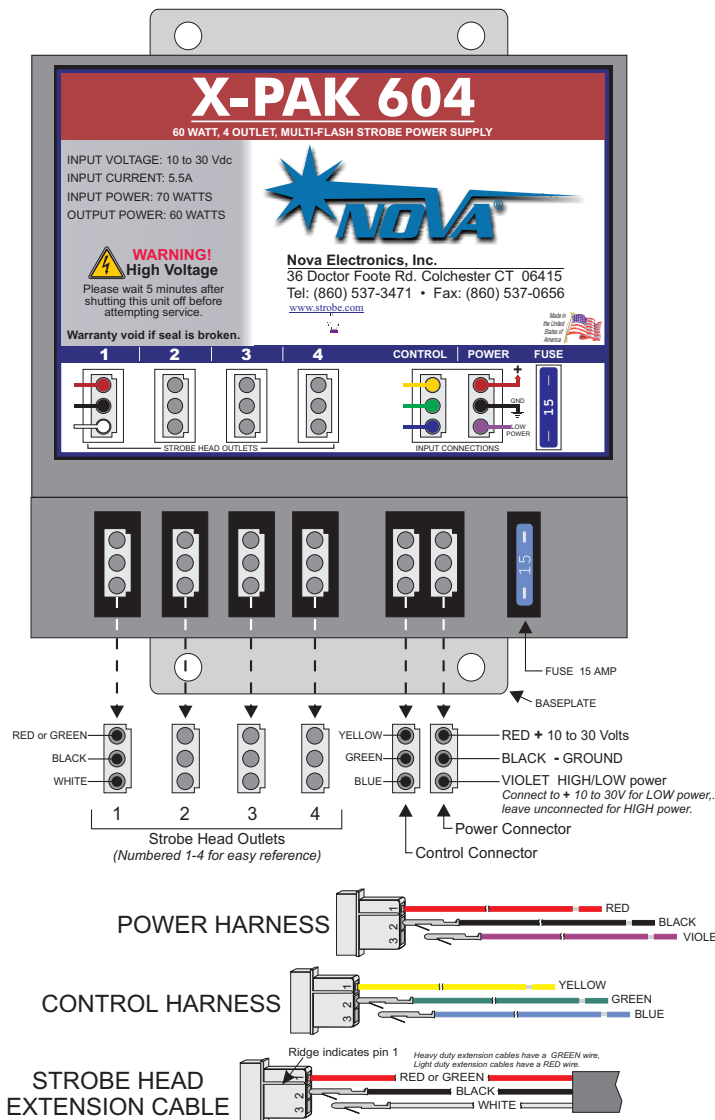

INSTALLING THE X-PAK 604

1. Mounting Considerations

Mount the power supply in a clean, dry location. Mounting the unit to a flat metal surface will aid in heat dissipation. Use the power supply as a template to mark the hole locations. The mounting holes will accept up to a 1/4" bolt. *Note: The power supply baseplate must be connected to chassis ground (GND) to reduce radio interference.*

2. Strobe Head installation

Plug the strobe light heads into the outlets. Keep the following in mind:

- Heads connected to outlets 1 and 3 flash at the same time.
- Heads connected to outlets 2 and 4 flash at the same time.
- Heads connected to 1 and 3 alternate with heads 2 and 4.

3. Electrical Hookup

If you have purchased a pre wired switch harness, follow the included instructions. If you are wiring the system yourself follow the instructions below and the diagrams on the next page.

POWER HARNESS:

- Connect the RED wire to battery positive (+) or a fuse panel circuit rated for at least 15 AMPS.
- Connect the BLACK wire to battery negative (-) or directly to vehicle chassis.

Note: Use the correct size wire for power connections.

The length of the wires determines the size needed.

1 to 10 ft. use 18AWG wire.

10 to 20 ft. use 16AWG wire.

20 to 35 ft. use 14AWG wire.

35 to 50 ft. use 12AWG wire.

- The VIOLET wire controls HIGH / LOW power. Low power limits the flash intensity for nighttime use. Connect VIOLET to +12/24V for LOW power, leave VIOLET disconnected for HIGH power.

CONTROL HARNESS:

- YELLOW, GREEN, BLUE wires select the flash pattern and also control which strobe head outlets are activated. A wire is 'selected' when connected to +12/24V. When all control wires are unconnected the power supply is in a low current SHUTDOWN MODE (Current is typically 25ma). See the PATTERN TABLE on the next page for a complete list of functions.

Note: VIOLET, YELLOW, GREEN and BLUE are all Low Current circuits and can be wired with a minimum of 22AWG wire.

WIRING/CONNECTION DIAGRAMS

DIAGRAM (1): ON/OFF and Low Power using two toggle switches. Flash pattern is: Quad Flash All Heads.

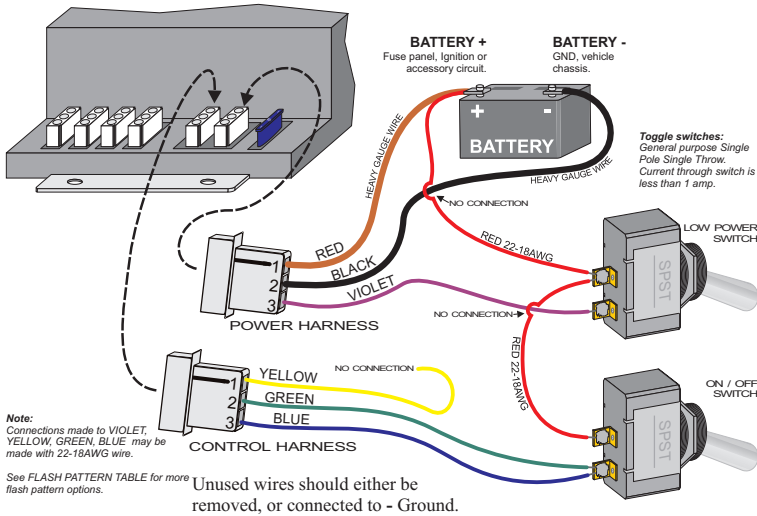

DIAGRAM (2): ON/OFF and Low Power using one DPDT rocker switch. Flash pattern is: Quad Flash All Heads.

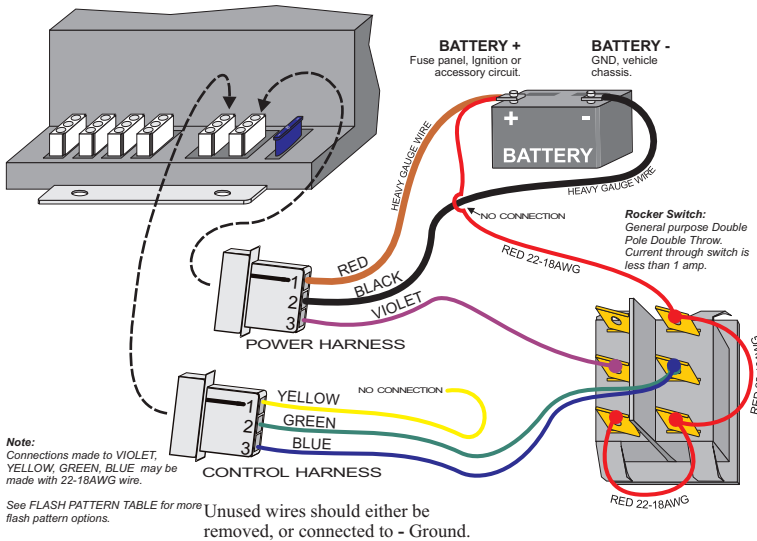
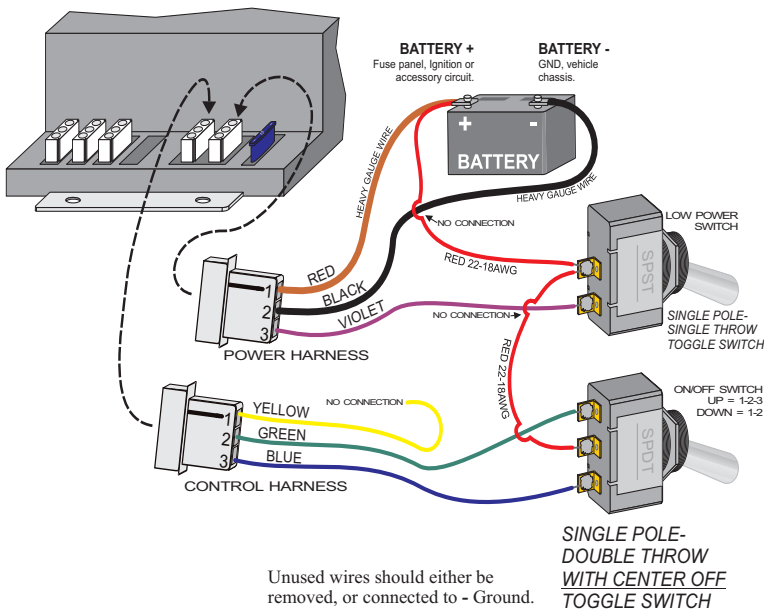

DIAGRAM (3): Selective switching of strobe head pairs. Low Power selection. Flash pattern is: Quad Flash All Heads.



PATTERN TABLE

Selecting a flash pattern: In the table below, find the desired flash pattern. Connect the wires marked **POWER** to the 'load' side of the ON/OFF switch. Remove the remaining wires, or connect them to - Ground.

Example: Diagram 1 uses pattern #4 (Quad Flash, All Heads). To change this to pattern #6 (Mega flash, All Heads) connect the YELLOW and BLUE wires to the switch.

PATTERN	YELLOW	GREEN	BLUE	FUNCTION
1				SHUTDOWN
2			POWER	Quad Flash, Head 2 ALT 3
3		POWER		Quad Flash, Head 1 ALT 4
4		POWER	POWER	Quad Flash, Head 1&3 ALT 2&4
5	POWER			Mega Flash, Head 2 ALT 3
6	POWER		POWER	Mega Flash, Head 1&3 ALT 2&4
7	POWER	POWER		Mega Flash, Head 1 ALT 4
8	POWER	POWER	POWER	When in High Power: Quintuple Flash, Head 1&3 ALT 2&4 When in Low Power: Double Flash, Head 1&3 ALT 2&4

ALT = "Alternates With"

TROUBLESHOOTING

Blown Fuse: The X-PAK 604 will blow a fuse if the input voltage is reversed. If this happens, first locate the wiring fault, then replace the fuse with one of the same rating.

Erratic behavior (and/or) shutdown: The X-PAK 604 will shut down if there is a short circuit condition on any one of the strobe heads. If the electrical conductors connecting the power supply to the strobe heads are exposed to water a short circuit will result. The first sign is intermittent operation, followed by complete shutdown of the strobe system. To find the short circuit, unplug all strobe head cables from the X-PAK 604. Test **one** cable/head at a time until the problem is found.

ACCESSORIES

The following accessories are available to make the installation of the X-PAK 604 power supply even easier:

ON/OFF - LOW POWER SWITCH PANEL

A Fully assembled switch panel which provides simple On/Off and Low power control. Provides the same functions as shown in Diagram (1)

SELECTIVE SWITCHING PANEL

A Fully assembled switch panel which allows selective switching of strobe head pairs and also includes Low power control. Provides the same functions as shown in Diagram (3)

ROTARY SWITCH PANEL

A fully assembled switch panel which provides full selection of all flash patterns as well as On/Off and Low Power control.

All panels are pre-wired with 15'(standard) of cabling.